

***Hustler® FasTrak®
CE Parts Manual***



HUSTLER®
ENGINEERING PERFORMANCE™

200 South Ridge Road
Hesston, Kansas
67062

Table of Contents

General Information

Service Literature	1-1
Options Available From Your Dealer.	1-1
Using This Manual	1-1
Hardware Description Codes & Abbreviations	1-2
Standard Torques	1-2

Section 2

Frame	2-2
Engine Guard & Hitch	2-4

Section 3

Hydraulic Transmission.	3-2
Transmission Service Parts	3-4
Steering.	3-6
Steering Assembly	3-10
Steering Box Assembly.	3-12

Section 4

Wheel & Tire	4-2
Front Wheel Breakdown—13 X 5 Tire	4-4
Front Wheel Breakdown—13 X 6.5 Tire	4-6
Drive Wheel Breakdown	4-8

Section 5

Engine.	5-2
Engine Service Parts.	5-6
Fuel System	5-8

Section 6

Battery & Fenders	6-2
Instrument Panel.	6-4

Section 7

48" Side Discharge Service Deck	7-2
48" Side Discharge Deck Pulleys & Spindles	7-4
48" Side Discharge Deck	7-6
54" Service Deck.	7-8
54" Deck Pulleys & Spindles.	7-10
54" Deck	7-12
48" Rear Discharge Service Deck.	7-14
48" Rear Discharge Deck Pulleys & Spindles.	7-16
48" Rear Discharge Deck	7-18
Rear Discharge Debris Shield.	7-20
Deck Lift	7-22

Section 8

Seat & Footrest.	8-2
Seat Service Parts	8-4
ROPS	8-6

General Information

This manual covers Hustler® FasTrak® models: **933424CE, 933432CE, & 934851CE.**

Service Literature

PART NO.	DESCRIPTION
605596	OPERATOR'S MANUAL
121353	WARRANTY STATEMENT
121363	GENERAL SERVICE MANUAL

Options Available From Your Dealer

PART NO.	DESCRIPTION
606045	SIDE CATCHER (NO ADAPTER KIT NEEDED)
933655	2-BAG CATCHER
121074	CATCHER ADAPTER KIT (48")
121075	CATCHER ADAPTER KIT (54")
121474	MULCH KIT (48")
121475	MULCH KIT (54")
121469	REAR DISCHARGE MULCH KIT (48")
600213	FLEX FORKS KIT (48")
605123	FLEX FORKS KIT (54")
121482	LIGHT KIT
121478	HIGH VACUUM KIT (48")
121479	HIGH VACUUM KIT (54")
333724	STEERING LEVER EXTENSION KIT
121472	STRIPE KIT
122166	SEAT ISOLATOR KIT

Note: When ordering parts, you must use the part number as shown for each part, not the index number. Always give the model and serial number to your parts and service representative.

Note: Items sold in bulk such as seals and hoses are sold by the foot.

Using This Manual

This manual is part of a service package for the Hustler® mowers. Use of this manual in conjunction with other Hustler® mower and component manuals will provide the information necessary to service and maintain Hustler® mowers.

This Parts Manual provides a complete parts listing for the unit. Use this manual when ordering parts. Illustrations used were current at the time of printing, but subsequent production changes may cause your machine to vary slightly in detail. Excel Industries, Inc. reserves the right to redesign and change the machine as deemed necessary, without notification. If a change has been made to your machine which is not reflected in this parts manual, see your authorized dealer for current information and parts.

The Service Manual is a service guide for use by Service Technicians. It provides the necessary information needed to perform normal maintenance requirements on these units.

The Operator's Manual provides fundamental operational information and operational safety that is needed when operating the mower.

The component manuals are furnished by the various manufacturers to be used for the troubleshooting and servicing of their products.

Hardware Description Codes & Abbreviations

The following codes are used throughout this parts manual. Refer to this list when ordering parts.

ABBREVIATION	DESCRIPTION	ABBREVIATION	DESCRIPTION
CB	CARRIAGE BOLT	MB	MACHINE BUSHING
CE	CLEVIS PIN	MS	MACHINE SCREW
CN	CLIP NUT	NT	NUT
CP	COTTER PIN	SC	SELF TAPPING CAP SCREW
CS	CAP SCREW	SH	SOCKET HEAD
CW	CUP WASHER	SB	SHOULDER BOLT
FDRW	FENDER WASHER	SS	SET SCREW
FW	FLAT WASHER	OD	OUTSIDE DIAMETER
HX	HEX HEAD	ID	INSIDE DIAMETER
LW	LOCK WASHER	WN	WELD NUT

Standard Torques

The following chart lists the standard torque values for the threaded fasteners found in this manual. Torque all cap screws, nuts and set screws to these values unless a different torque is shown in the Notes section next to the fastener.

SIZE	FT-LBS	N•M	SIZE	FT-LBS	N•M
.250	8.2	11.1	M3	1	1.3
.312	17	23	M4	2.2	3
.375	30	40	M5	4.5	6.1
.438	48	65	M6	7.7	10.4
.500	73	99	M8	18.5	25
.562	105	143	M10	37	50
.625	145	200	M12	64	87
.750	260	350	M14	80	108.5
.875	420	565	M16	160	215
1.00	625	850	M20	320	435
			M24	555	750

Section 2

Frame	2-2
Engine Guard & Hitch	2-4

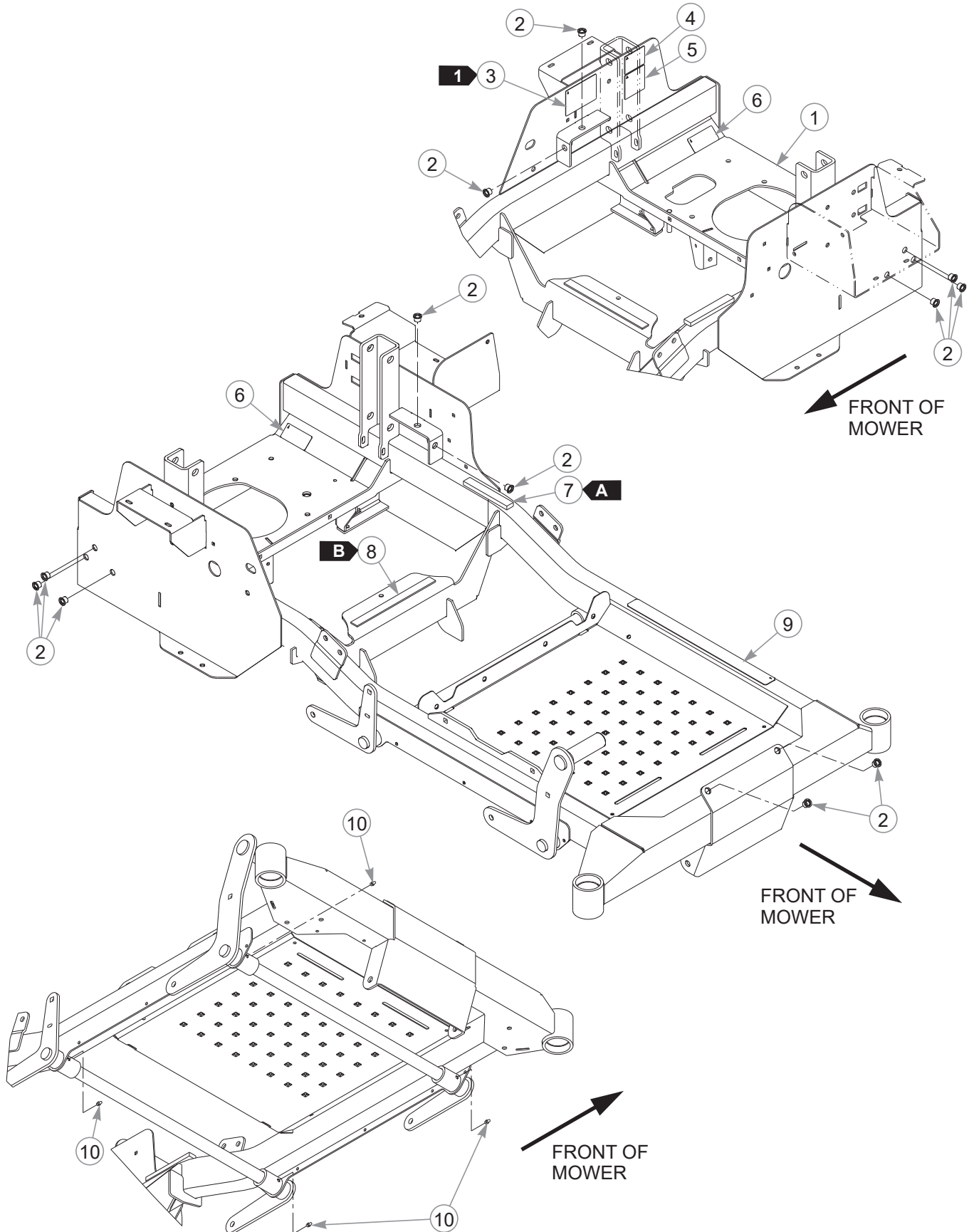

Frame



Frame

INDEX NO.	PART NO.	QTY.	DESCRIPTION
1	553087	1	48" FRAME (WITH DECALS & HARDWARE)
	553088	1	54" FRAME (WITH DECALS & HARDWARE)
2	808493	12	3/8-16 THREAD RIVET NUT
3	N/A	1	SERIAL NUMBER / SPEC DECAL
4	776310	1	CE MARK DECAL
5	789776CE	1	CE 105 DBA LIMIT DECAL
6	602041	2	HOT DECAL
7	713198	13 cm	SEAL 3/8 X 3/4
8	033035	23 cm	WEATHERSTRIP
9	601993	1	SAFE OPERATION DECAL
10	015495	4	GREASE FITTING STRAIGHT

NOTES:

SEAL/WEATHERSTRIP LENGTHS	
	13 cm
	23 cm

1. Serial number decal. In the event the serial number decal becomes damaged or illegible, please contact your dealer to order a replacement.

Engine Guard & Hitch

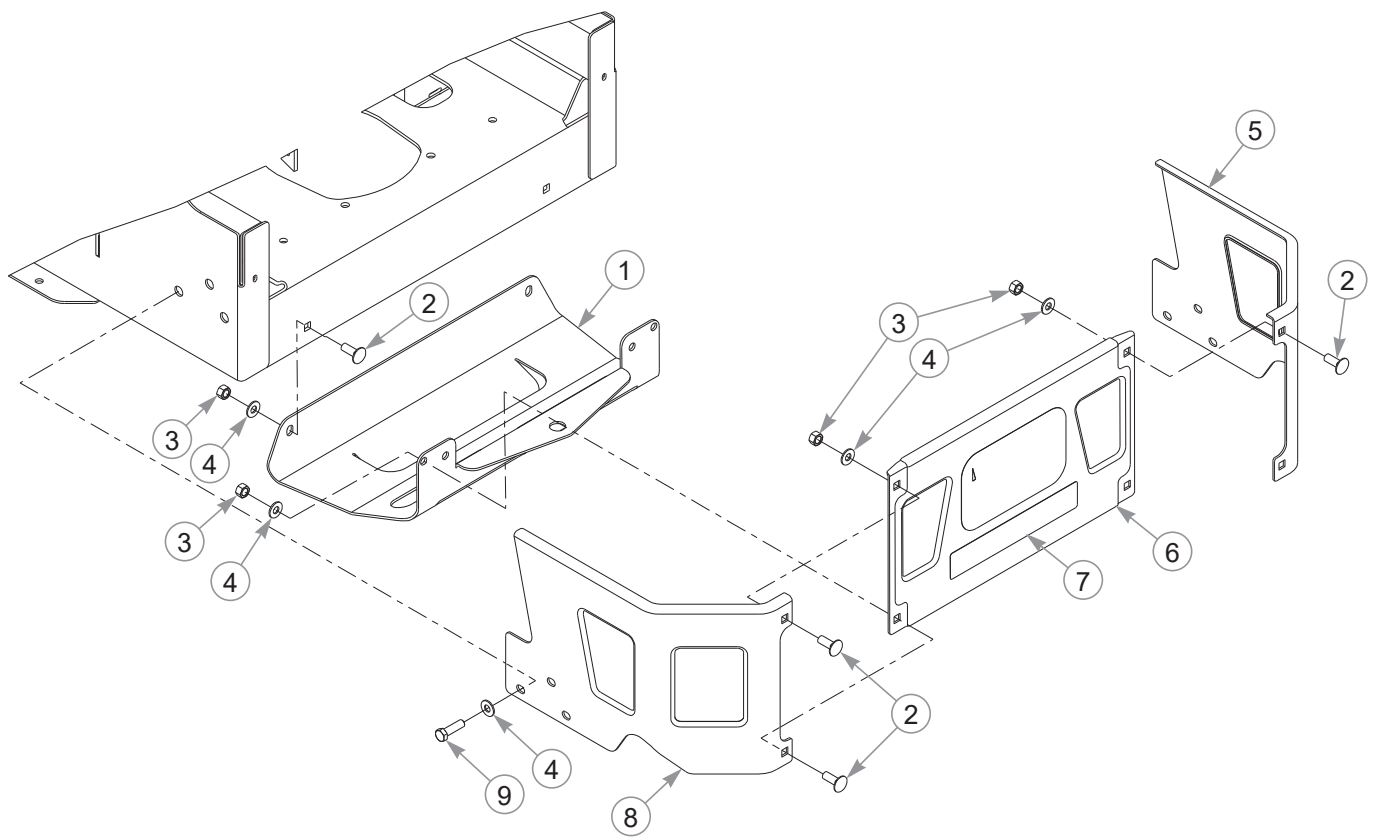

Engine Guard & Hitch

INDEX NO.	PART NO.	QTY.	DESCRIPTION
1	119977	1	HITCH PLATE
2	025395	6	CB .375-16 X 1.00 G5 ZNY
3	054502	6	NT .375-16 HX G5 ZNY
4	767954	12	FW .379 X .813 X .063
5	121134	1	RS GUARD
6	553123	1	CENTER GUARD (WITH DECAL)
7	604770	1	H LOGO DECAL
8	121133	1	LS GUARD
9	052860	6	CS .375-16 X 1.25 HX G5 ZN

NOTES:

Section 3

Hydraulic Transmission	3-2
Transmission Service Parts	3-4
Steering	3-6
Steering Assembly	3-10
Steering Box Assembly	3-12

Hydraulic Transmission

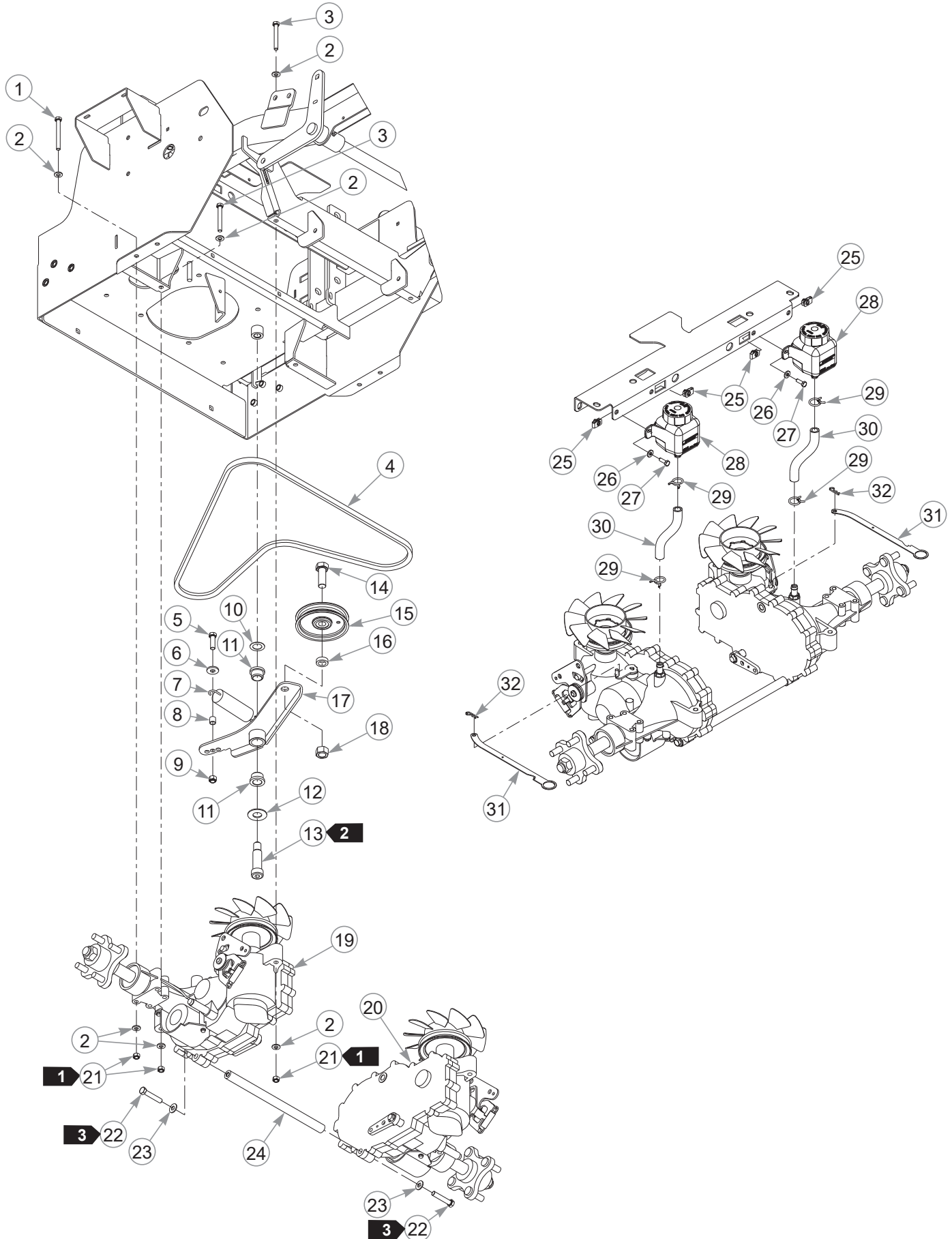

Hydraulic Transmission

INDEX NO.	PART NO.	QTY.	DESCRIPTION
1	043067	4	CS .312-18 X 3.00 HX G5 Z
2	768523	16	FW .343 X .687 X .051/.080H
3	710087	4	CS .312-18 X 2.50 HX G5
4	605468	1	BELT, A-SEC
5	052860	1	CS .375-16 X 1.25 HX G5
6	712919	1	FW .406 X 1.00 X .12 HRD Z
7	036384	1	SPRING 1/4 COIL PL 1.23
8	605481	1	BUSHING
9	086660	1	NT .375-16 HX G5 ZY NL
10	704791	1	FW .781 X 1.25 X .024 ZN
11	781153	2	BUSHING
12	025296	1	FW .760 X 1.625 X .08
13	601084	1	SB .750 X 2.00 SH .625-11
14	025007	1	CS .625-11 X 1.75 HX G5
15	786848	1	IDLER PULLEY
16	600296	1	DECK IDLER SPACER
17	123271	1	TENSION ARM
18	016972	1	NT .625-11 HX G5 ZNYC
19	605235	1	RS TRANSMISISON
20	605234	1	LS TRANSMISSION
21	058776	8	NT .312-18 HX G5 ZY NL
22	016410	2	CS .375-16 X 2.00 HX G5
23	767954	2	FW .379 X .813 X .063
24	600987	1	SPACER TUBE
25	601982	4	CN .250-20 X .15 MAX THK
26	768515	4	FW .281 X .625 X .066
27	055939	4	CS .250-20 X .75 HX G5
28	605217	2	SINGLE FITTING RESERVOIR
	600767	2	RESERVOIR CAP
29	601001	4	SPRING CLAMP
30	605218	2	OVERFLOW HOSE
31	120126	2	TOW VALVE LINK
32	706549	2	HP .080D X 1.19

NOTES:

1. Torque to 23 N•m.
2. Torque to 135 N•m.
3. Torque to 41 N•m.

Transmission Service Parts

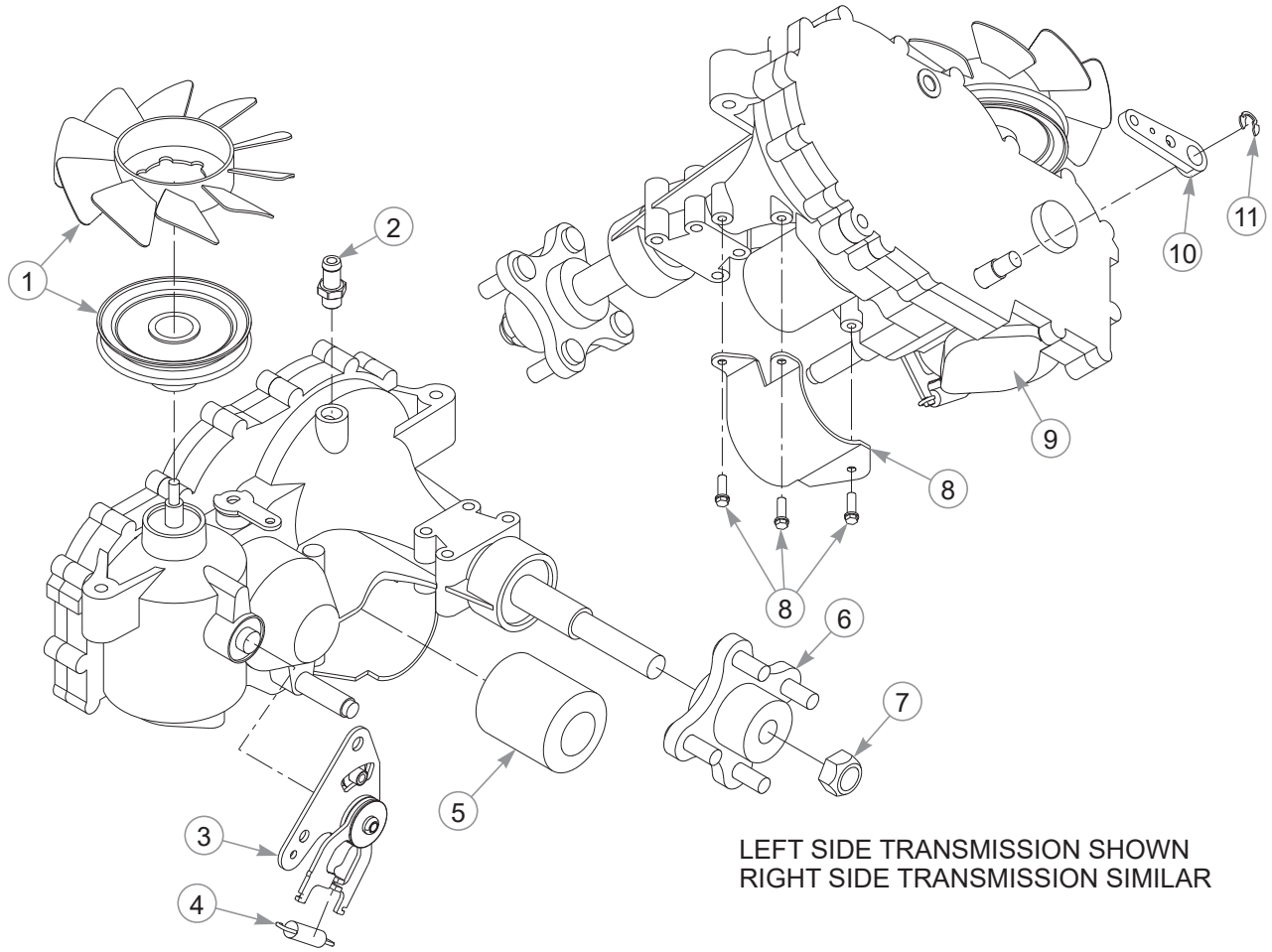

LEFT SIDE TRANSMISSION SHOWN
RIGHT SIDE TRANSMISSION SIMILAR

INDEX NO.	PART NO.	QTY.	DESCRIPTION
1	601941	1	FAN/PULLEY KIT
2	605608	1	TRANSMISSION FITTING
3	605778	1	RTN, LEFT (INCLUDES SPRING)
	605779	1	RTN, RIGHT (INCLUDES SPRING)
4	604903	1	HG RTN SPRING
5	600976	1	OIL FILTER
6	601433	1	4-BOLT HUB KIT (INCLUDES NUT)
7	788877	1	HUB NUT
8	600975	1	LS FILTER GUARD KIT (WITH BOLTS)
	600974	1	RS FILTER GUARD (NOT SHOWN)
9	603572	1	CHARGE COVER KIT (WITH BOLTS)
10	601221	1	BRAKE ARM
11	600972	1	RETAINING CLIP
12	603223	1	O-RING (NOT SHOWN)

NOTES:

This page intentionally left blank.

Steering

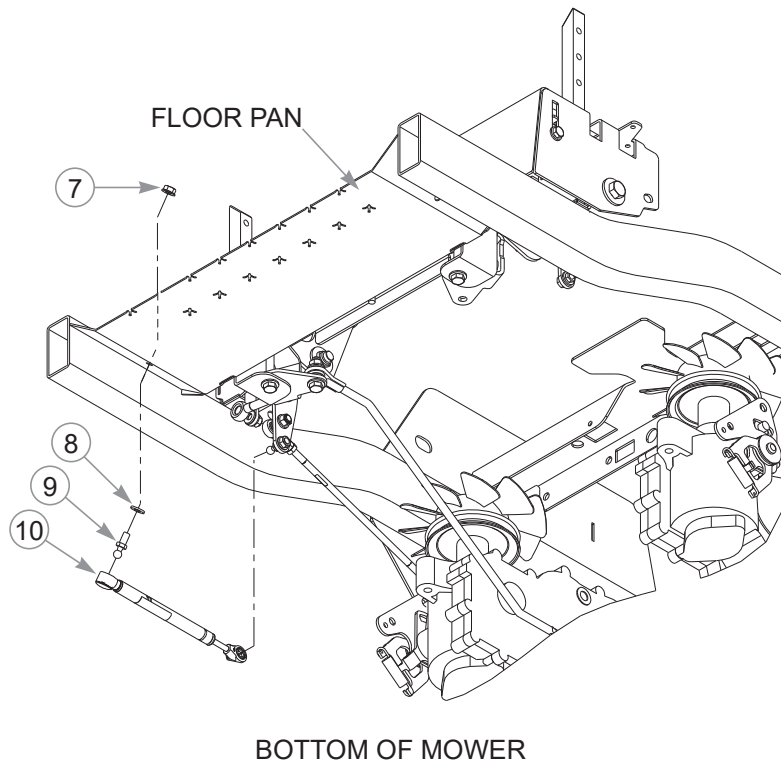
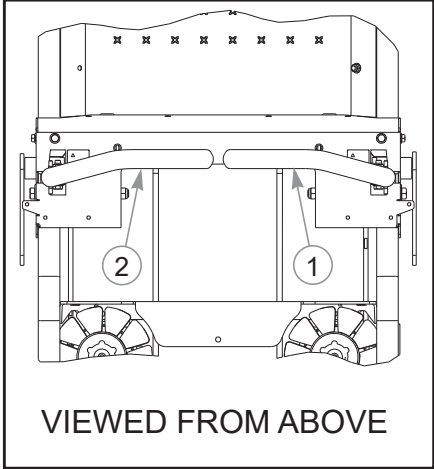
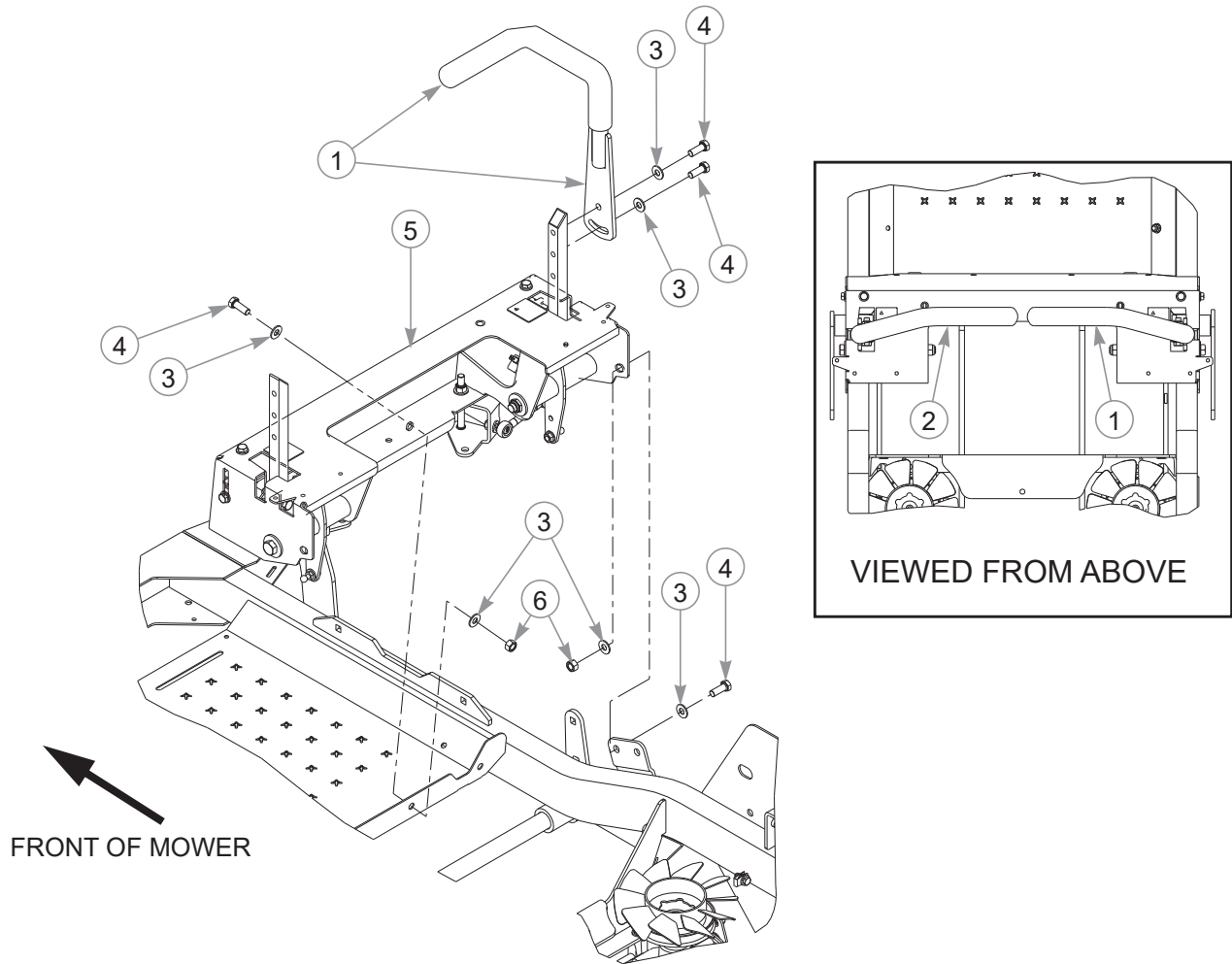

Steering

INDEX NO.	PART NO.	QTY.	DESCRIPTION
1	605383	1	STEERING BAR RS (WITH GRIP)
2	605384	1	STEERING BAR LS (WITH GRIP)
	781260	1	STEERING BAR GRIP
3	767954	24	FW .379 X .813 X .063
4	036244	10	CS .375-16 X 1.00 HX G5
5	N/A	1	STEERING ASSEMBLY
6	054502	6	NT .375-16 HX G5 ZNY
7	016832	2	NT .312-18 HX FLK ZNYC
8	768523	10	FW .343 X .687 X .051/.080H
9	781922	2	BALL STUD
10	603983	2	DAMPER

NOTES:

Steering

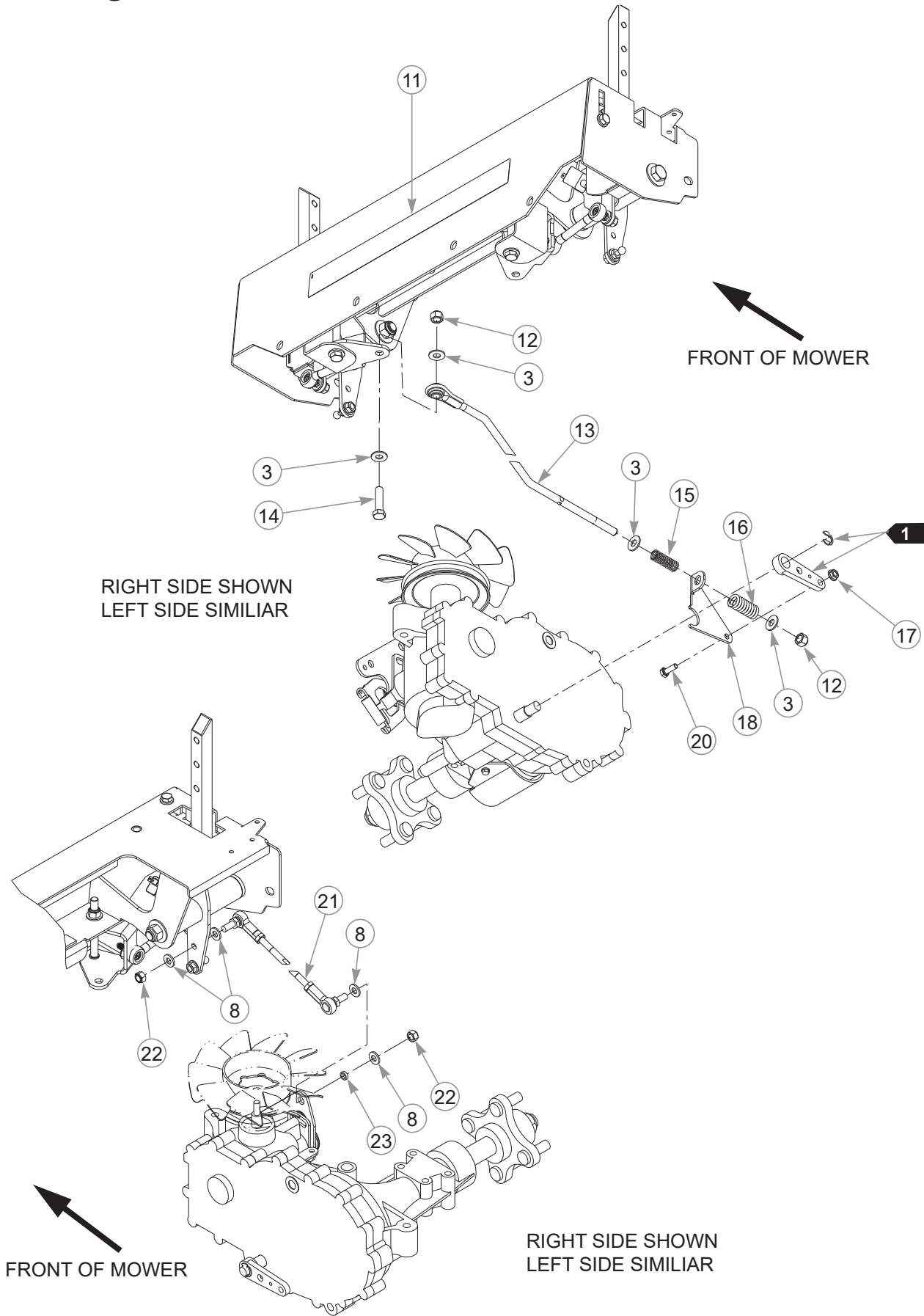

Steering

INDEX NO.	PART NO.	QTY	DESCRIPTION
11	605591	1	DECAL
12	086660	4	NT .375-16 HX G5 ZY NL
13	605145	2	BRAKE ROD ASSEMBLY
14	080655	2	CS .375-16 X 1.50 HX G5
15	601131	2	SPRING
16	601051	2	OVERTRAVEL SPRING
17	016816	2	NT .250-20 HX G5 FL LK ZNY
18	120671	1	RS BRAKE SPRING LINK
19	120672	1	LS BRAKE SPRING LINK (NOT SHOWN)
20	055939	2	CS .250-20 X .75 HX G5
21	600981	2	PUMP ROD
22	023655	4	NT .312-24 HX NL G5
23	604456	2	SPACER

NOTES:

1. Part of the transmission.

Steering Assembly

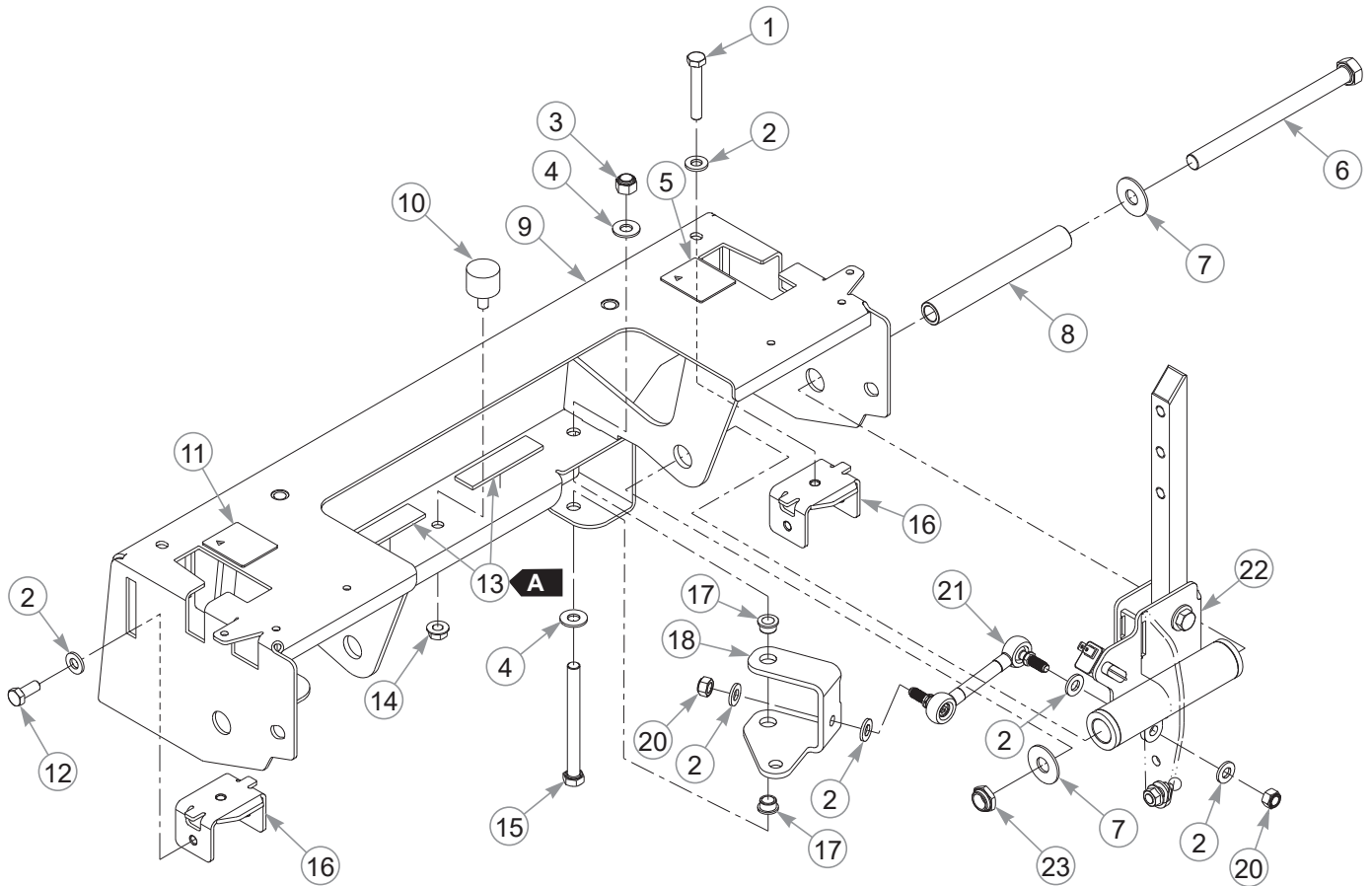

RIGHT SIDE SHOWN
LEFT SIDE SIMILAR

Steering Assembly

INDEX NO.	PART NO.	QTY.	DESCRIPTION
1	064345	2	CS .312-18 X 2.00 HX G5
2	768523	12	FW .343 X .687 X .051/.080H
3	086660	2	NT .375-16 HX G5 ZY NL
4	767954	4	FW .379 X .813 X .063
5	785220	1	RS STEERING DECAL
6	042630	2	CS .500-13 X 6.50 HX G5 Z
7	712976	4	FW .531 X 1.375 X .125
8	119811	2	SPACER
9	552852	1	STEERING COVER (WITH DECALS)
10	605542	1	ISOLATOR
11	785139	1	LS STEERING DECAL
12	034280	2	CS 0.312-18 X .75 HX G5
13	033035	15 cm	WEATHERSTRIP
14	016832	1	NT .312-18 HX FLK ZNYC
15	725796	2	CS .375-16 X 4.00 HX G8 Z
16	605518	2	STEERING STOP
17	765339	4	BUSHING
18	124353-1	1	RS BRAKE BELL CRANK
19	124352-1	1	LS BRAKE BELL CRANK (NOT SHOWN)
20	058776	4	NT .312-18 HX G5 ZY NL
21	604179	2	BRAKE ROD
22	N/A	1	STEERING BOX ASSEMBLY
23	707398	2	NT .500-13 JAM NY LK

NOTES:

WEATHERSTRIP LENGTH	
	7.5 cm

Steering Box Assembly

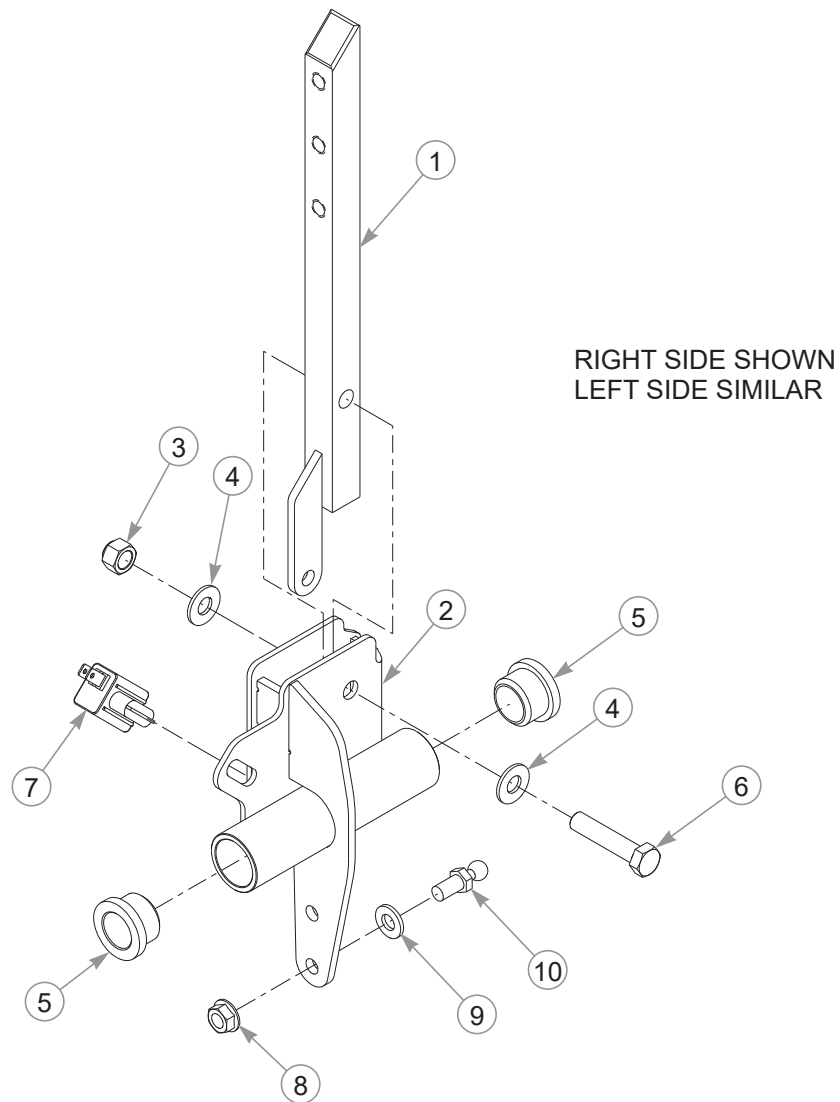

INDEX NO.	PART NO.	QTY.	DESCRIPTION
1	119807	1	STEER LEVER
2	119750	1	RS STEER PIVOT
	119749	1	LS STEER PIVOT (NOT SHOWN)
3	086660	1	NT .375-16 HX G5 ZY NL
4	767954	2	FW .379 X .813 X .063
5	781153	2	BUSHING
6	705178	1	CS .375-16 X 1.75 HX G5
7	601087	1	SWITCH
8	016832	1	NT .312-18 HX FLK ZNYC
9	768523	1	FW .343 X .687 X .051/.080H
10	781922	1	BALL STUD

NOTES:

Section 4

Wheel & Tire	4-2
Front Wheel Breakdown—13 X 5 Tire	4-4
Front Wheel Breakdown—13 X 6.5 Tire	4-6
Drive Wheel Breakdown	4-8

Wheel & Tire

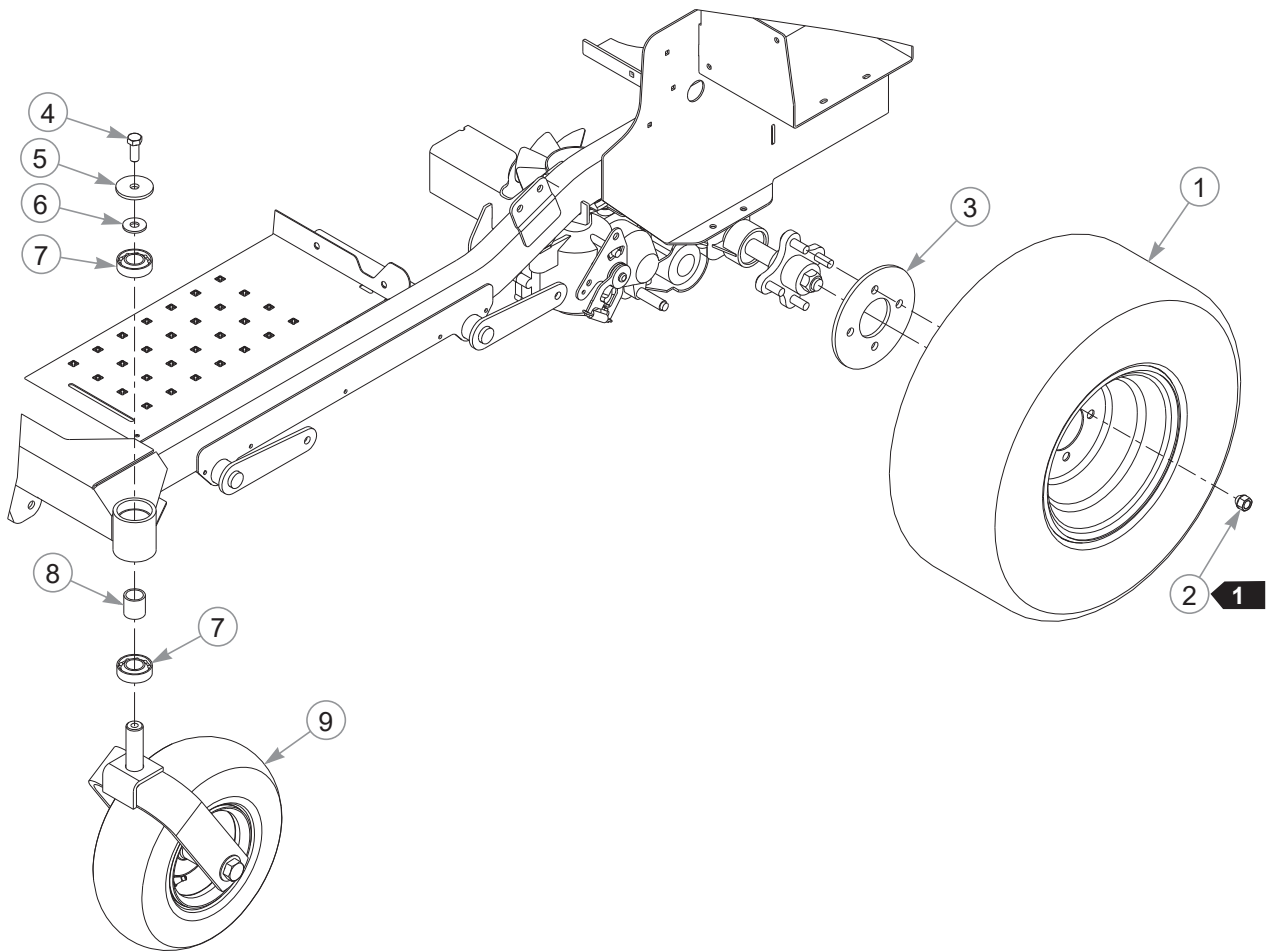

Wheel & Tire

INDEX NO.	PART NO.	QTY.	DESCRIPTION
1	605484	2	TIRE/WHEEL ASSEMBLY (48" MOWERS)
	605728	2	TIRE/WHEEL ASSEMBLY (54" MOWERS)
2	061077	8	WHEEL NUT
3	111875-1	2	WHEEL BACKUP PLATE
4	705954	2	CS .500-13 X 1.25 HX G5
5	344267	2	FW .510 X 2.15 X .187 SPL
6	712976	2	FW .531 X 1.375 X .125
7	784223	4	BEARING
8	784603	2	SPACER
9	N/A		FRONT TIRE ASSEMBLY

NOTES:

1. Torque to 88–102 N•m.

Front Wheel Breakdown—13 X 5 Tire

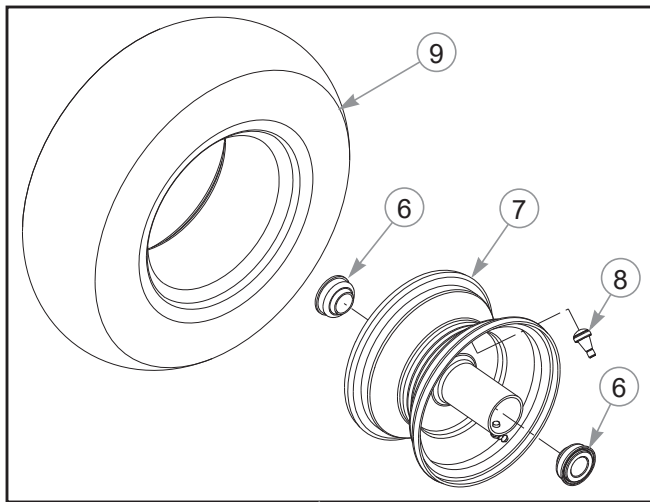
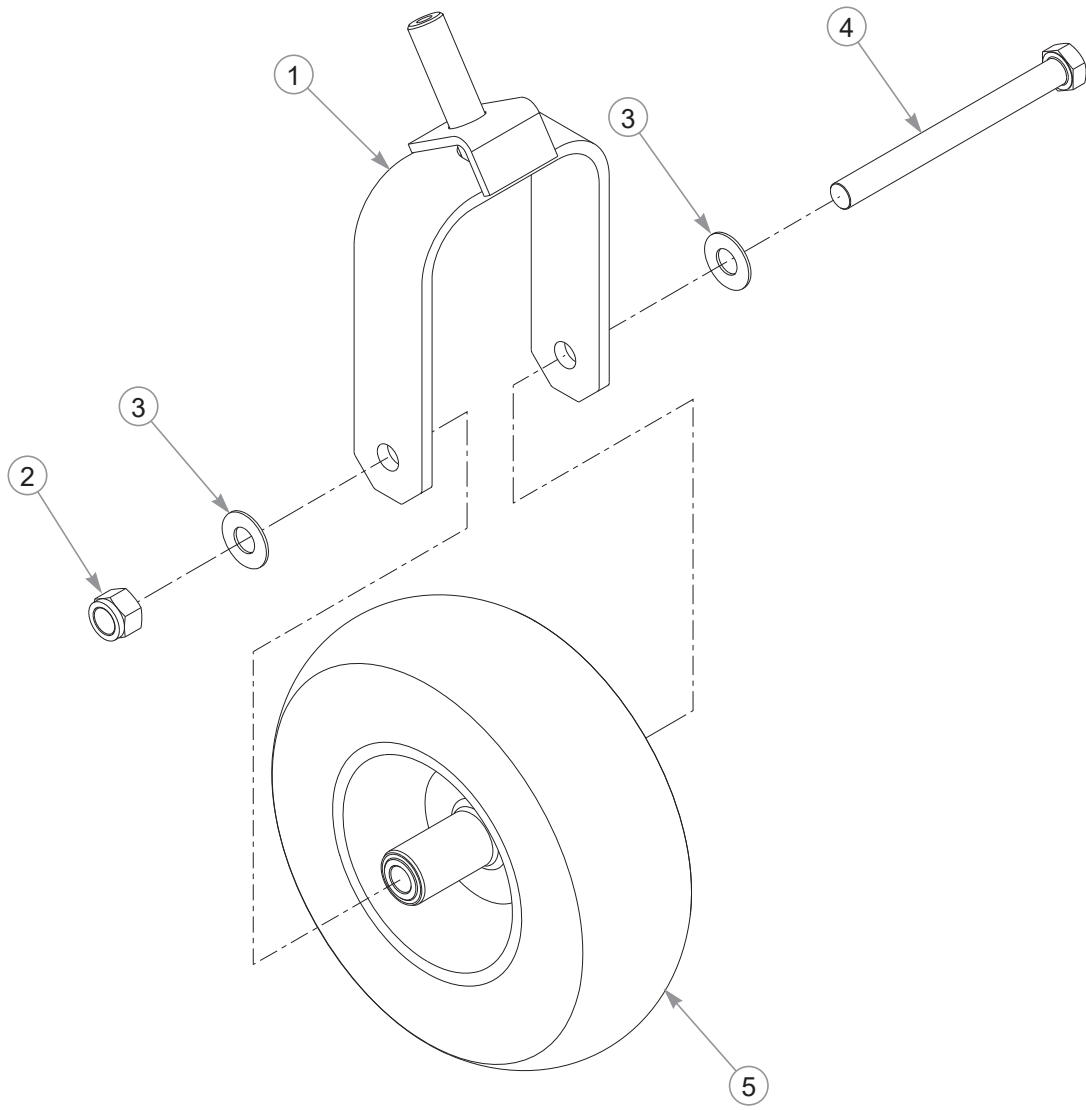

Front Wheel Breakdown—13 X 5 Tire

INDEX NO.	PART NO.	QTY.	DESCRIPTION
1	366625	1	FORK
2	061101	1	NT .750-10 HX ZY NL
3	025296	2	FW .760 X 1.625 X .08
4	786731	1	CS .750-10 X 8.00 HX G5
5	605038	1	TIRE/WHEEL 13 X 5.00
6	786103	2	WHEEL BEARING
7	786079	1	WHEEL 6 X 3.25
8	019521	1	VALVE STEM
9	605039	1	TIRE 13 X 5

NOTES:

Front Wheel Breakdown—13 X 6.5 Tire

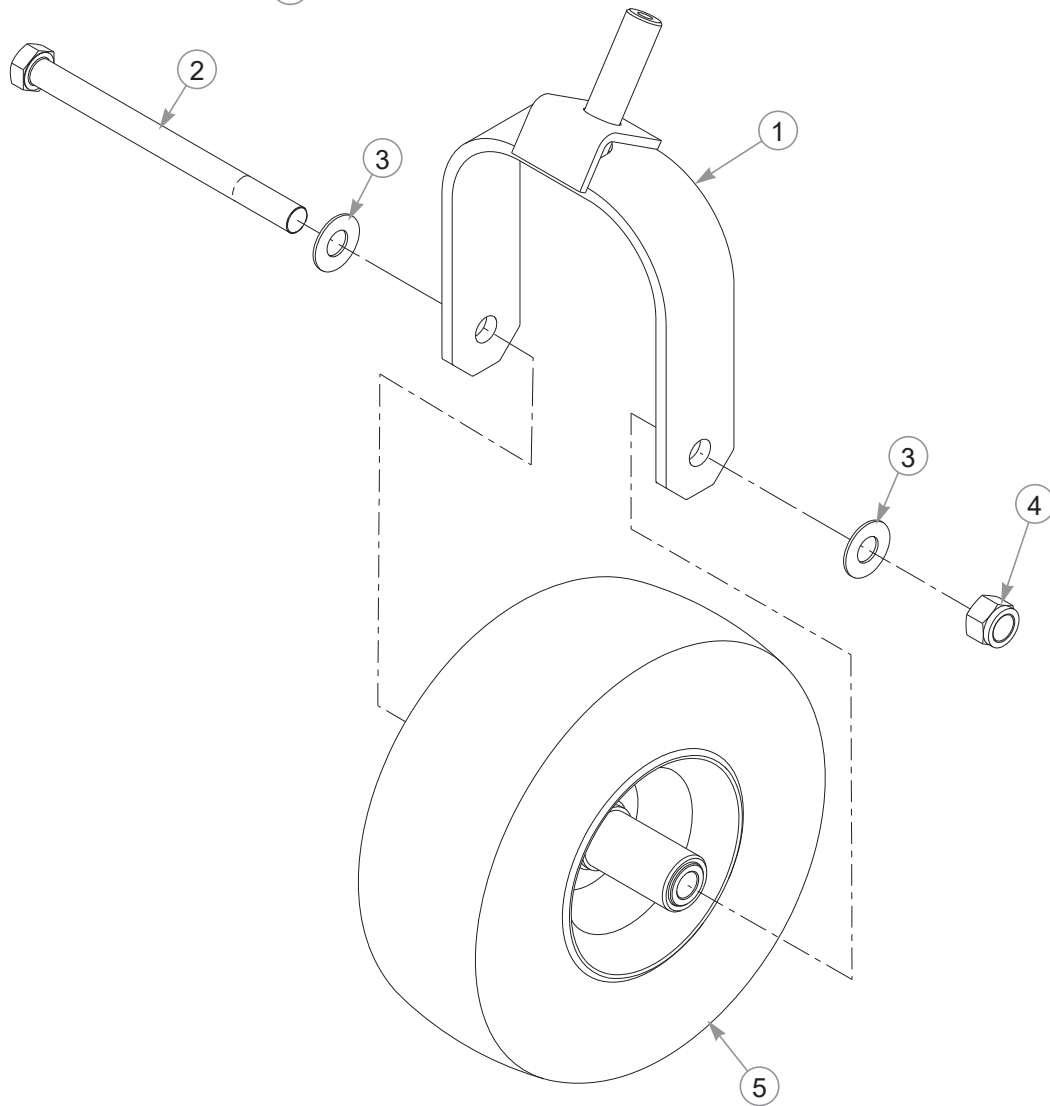
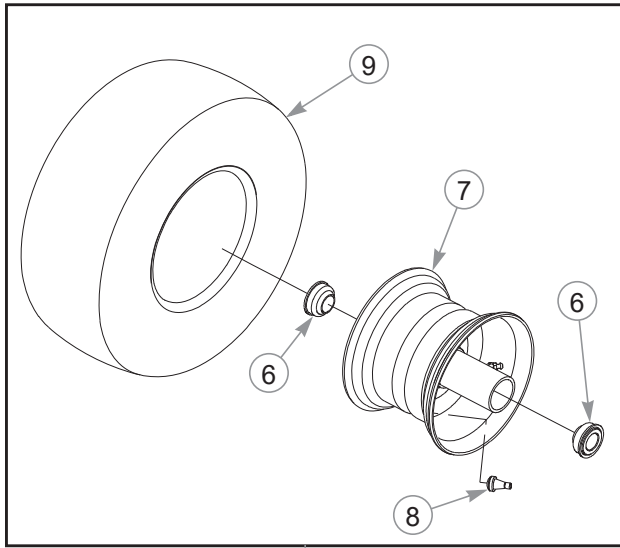

Front Wheel Breakdown—13 X 6.5 Tire

INDEX NO.	PART NO.	QTY	DESCRIPTION
1	604691	1	FORK
2	041475	1	CS .750-10 X 9.50 HX ZY
3	025296	2	FW .760 X 1.625 X .08
4	061101	1	NT .750-10 HX ZY NL
5	605197	1	TIRE/WHEEL ASSY 13 X 6.50
6	786103	2	WHEEL BEARING
7	605200	1	WHEEL, 6 X 4.5
8	019521	1	VALVE STEM
9	604843	1	TIRE 13 X 6.5

NOTES:

Drive Wheel Breakdown

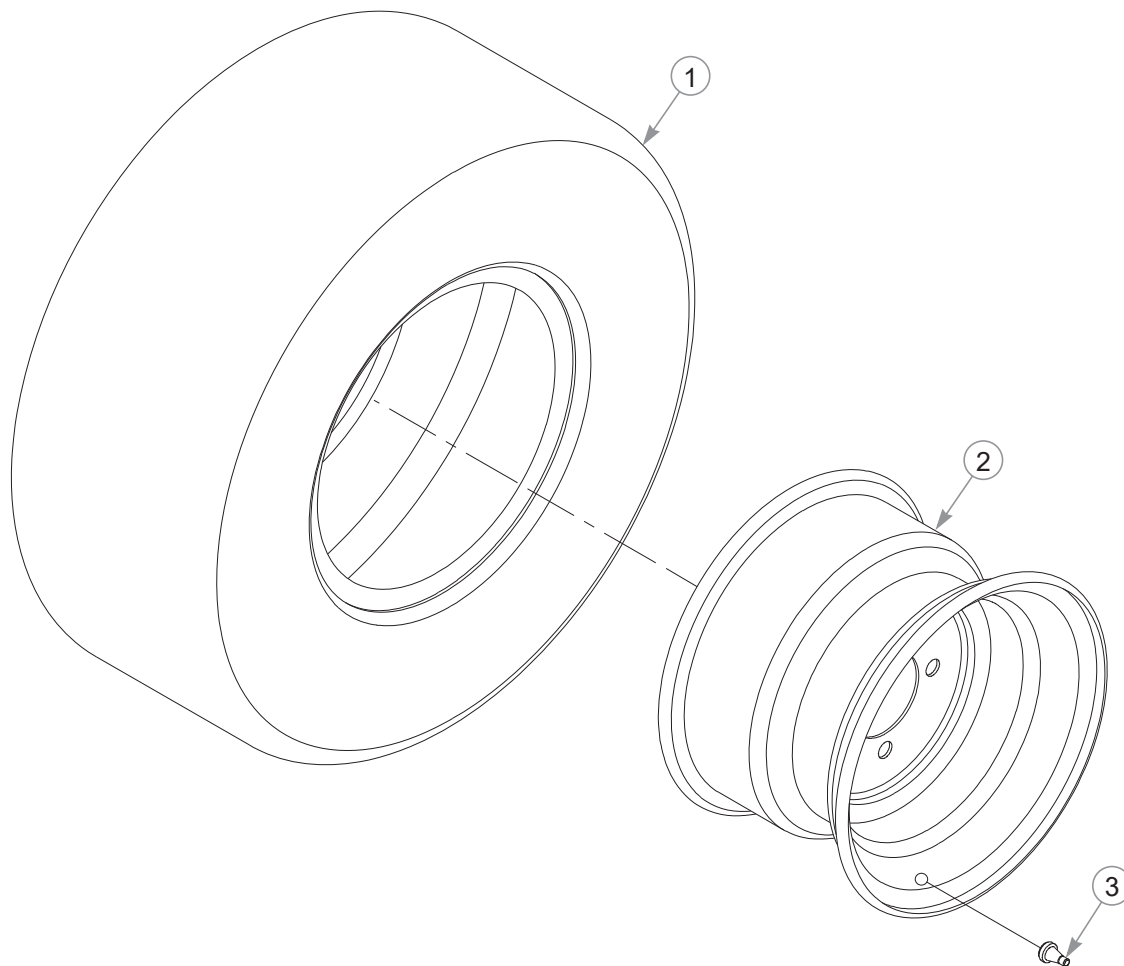

605484 TIRE & WHEEL ASSEMBLY (48" MOWERS)

INDEX NO.	PART NO.	QTY.	DESCRIPTION
1	605485	1	TIRE 22 X 9.5-10
2	600700	1	WHEEL 10 X 7
3	019521	1	TIRE VALVE

605302 TIRE & WHEEL ASSEMBLY (54" MOWERS)

INDEX NO.	PART NO.	QTY.	DESCRIPTION
1	605737	1	TIRE 22 X 11-10
2	601347	1	WHEEL 10 X 8.5
3	019521	1	TIRE VALVE

NOTES:

Section 5

Engine	5-2
Engine Service Parts	5-6
Fuel System	5-8

Engine

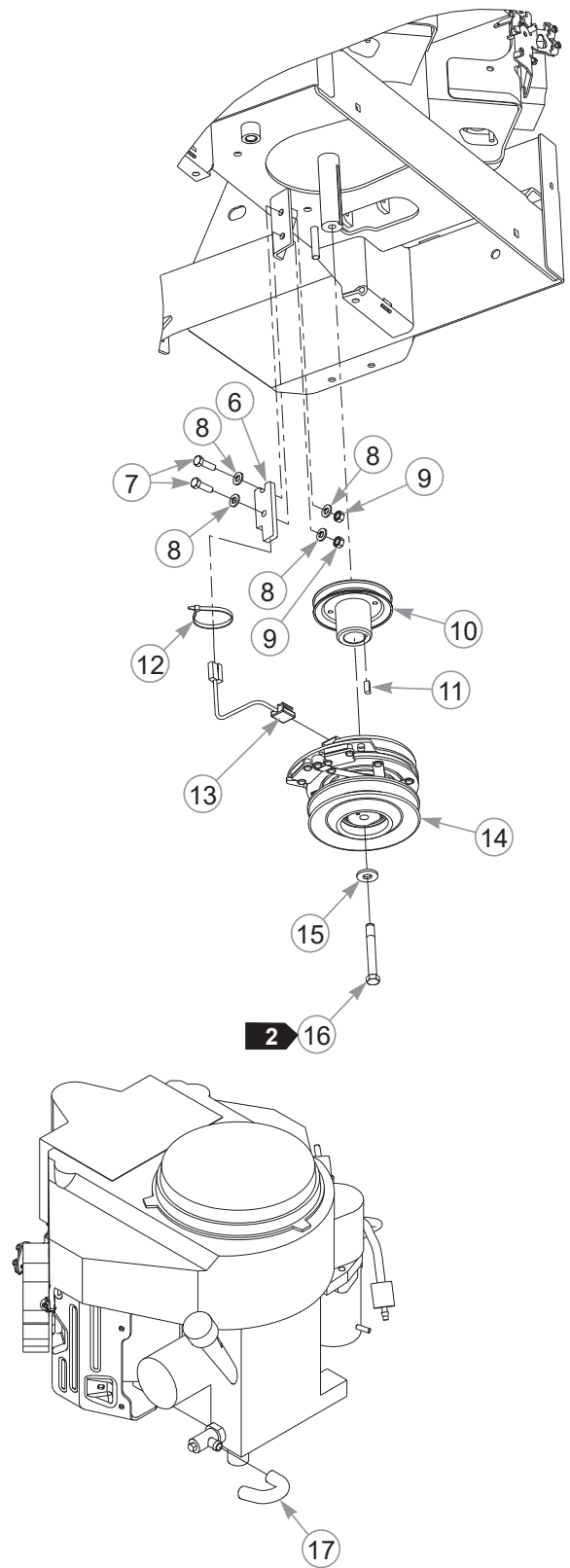
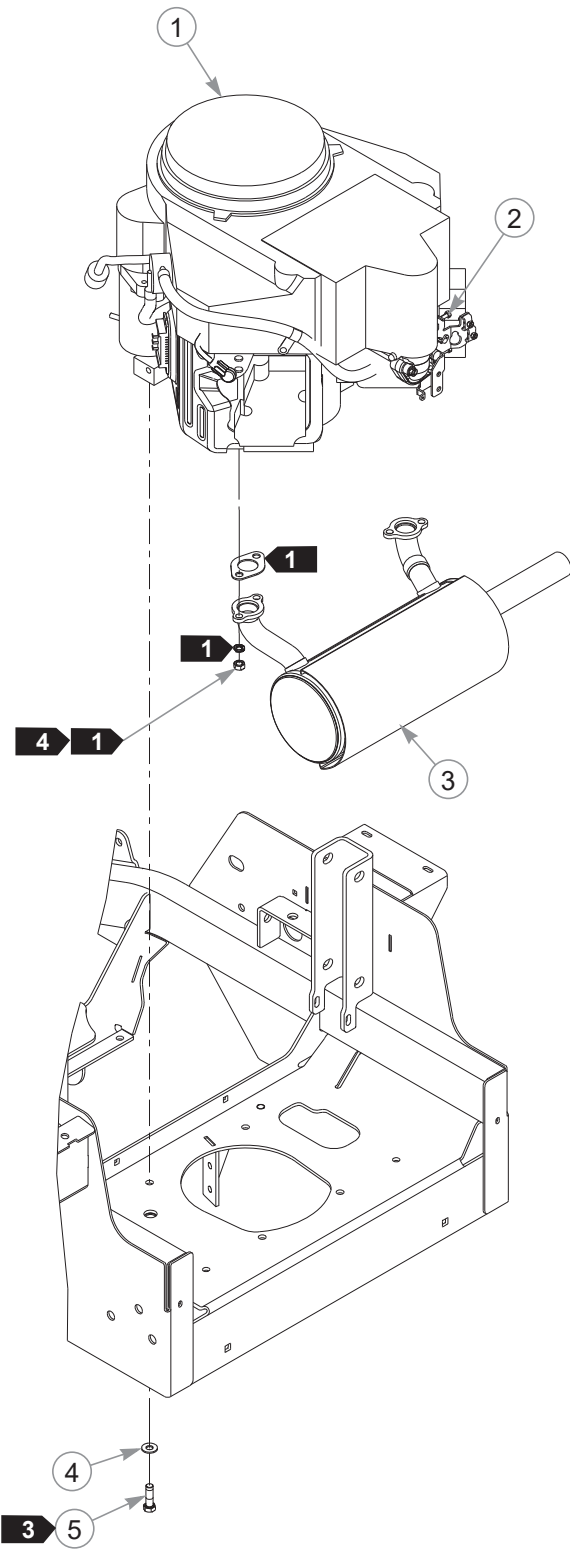

Engine

INDEX NO.	PART NO.	QTY.	DESCRIPTION
1	N/A	1	ENGINE, KAWASAKI FR691V & FR730V
2	603524	1	CS M5-.8 X 50 MM DIN 933 (FUL TD)
3	604250	1	MUFFLER
4	767954	4	FW .379 X .813 X .063
5	602580	4	CS .375-16 X 1.25 HX G8 P85
6	113946	1	CLUTCH ANCHOR
7	036236	2	CS .312-18 X 1.00 HX G5
8	768523	5	FW .343 X .687 X .051/.080H
9	034272	2	NT .312-18 HX G5
10	605490	1	PULLEY
11	712372	1	KEY 1/4 SQ X .66 LG
12	000331	5	WIRE TIE
13	791251	1	CLUTCH HARNESS PIGTAIL
14	121773K	1	CLUTCH KIT
15	602680	1	FW .453 X 1.12 X .119 HRD
16	601834	1	CS .437-20 X 3.25 HX G5 P85
17	605317	1	OIL DRAIN HOSE

NOTES:

1. Supplied with the engine.
2. Torque to 61 N•m.
3. Torque to 41–47 N•m.
4. Torque to 23 N•m.

Engine

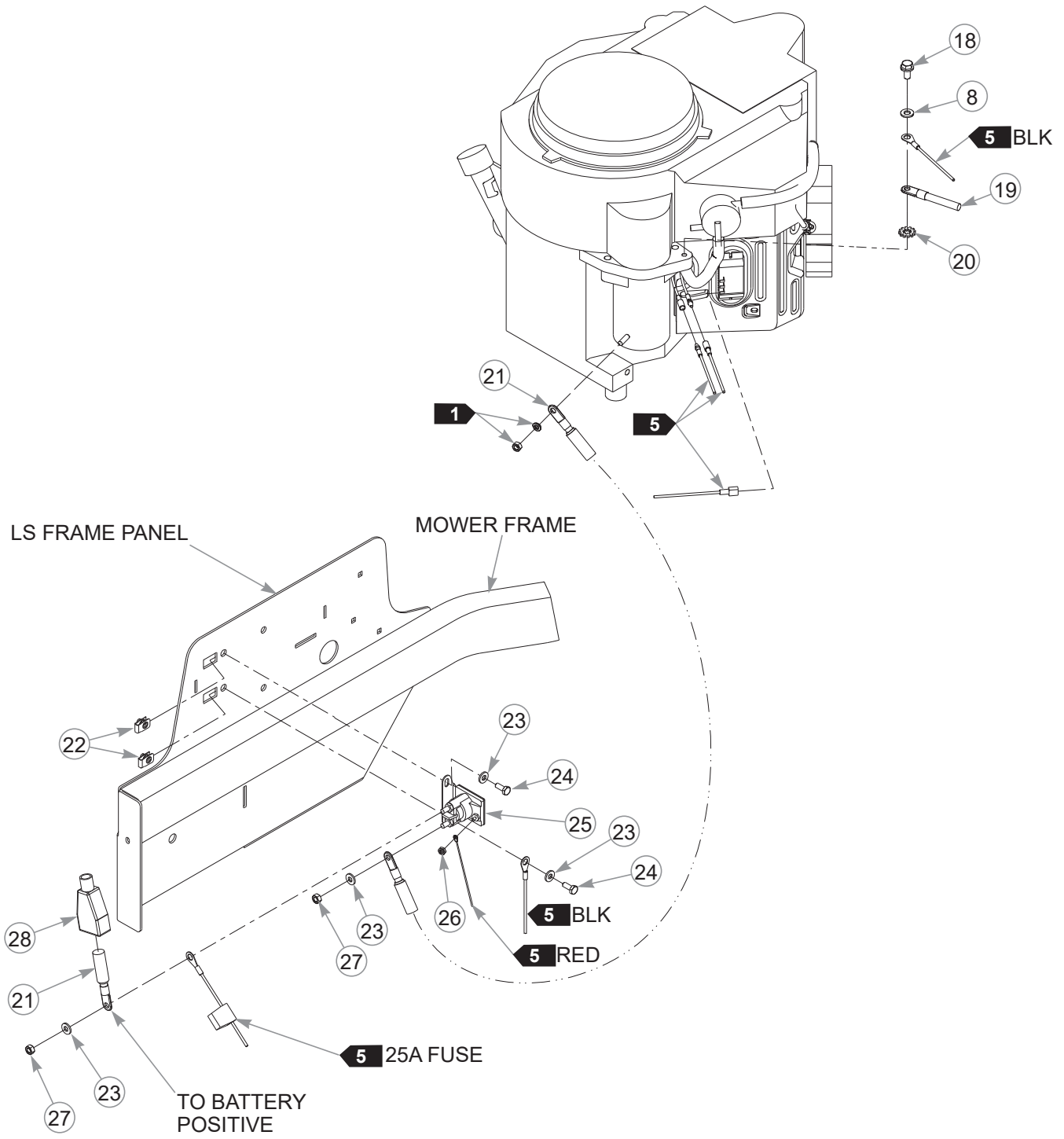

Engine

INDEX NO.	PART NO.	QTY.	DESCRIPTION
18	720516	1	CS M8 X 1.25 X 16 HX FL 10.9
19	601841	1	NEGATIVE BATTERY CABLE
20	029876	1	LW .325 INT-EXT TOOTH
21	601840	2	POSITIVE BATTERY CABLE
22	601982	2	CN .250-20 X .15 MAX THK
23	768515	4	FW .281 X .625 X .066
24	064329	2	CS .250-20 X .625 HX G5
25	030817	1	STARTER SOLENOID
26	044255	1	NT #10-32 HX ZN
27	024927	2	NT .250-20 HX G5
28	771428	1	RED BATTERY CABLE BOOT

NOTES:

5. Part of the wire harness.

Engine Service Parts

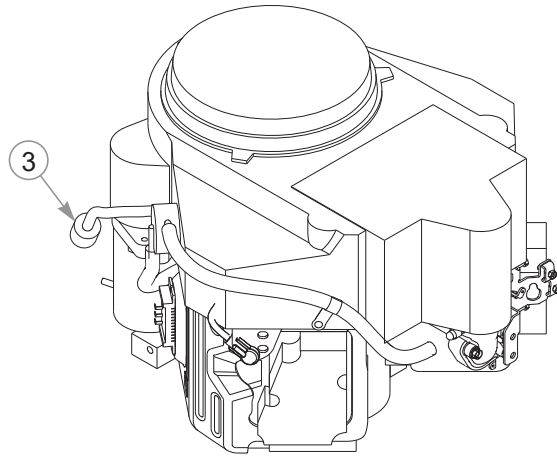
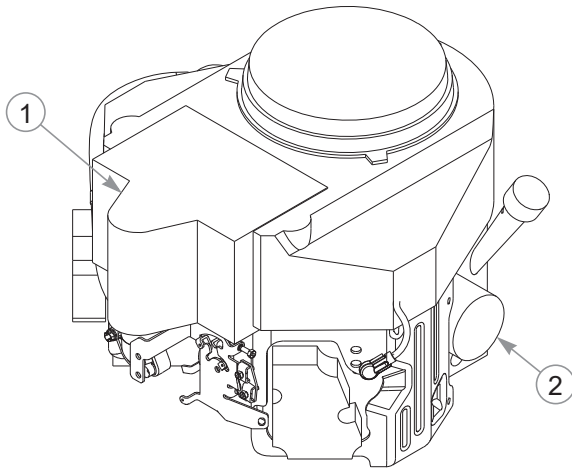

INDEX NO.	PART NO.	QTY.	DESCRIPTION
1	603059	1	AIR FILTER
2	602581	1	OIL FILTER
3	068478	1	IN-LINE FUEL FILTER

NOTES:

This page intentionally left blank.

Fuel System

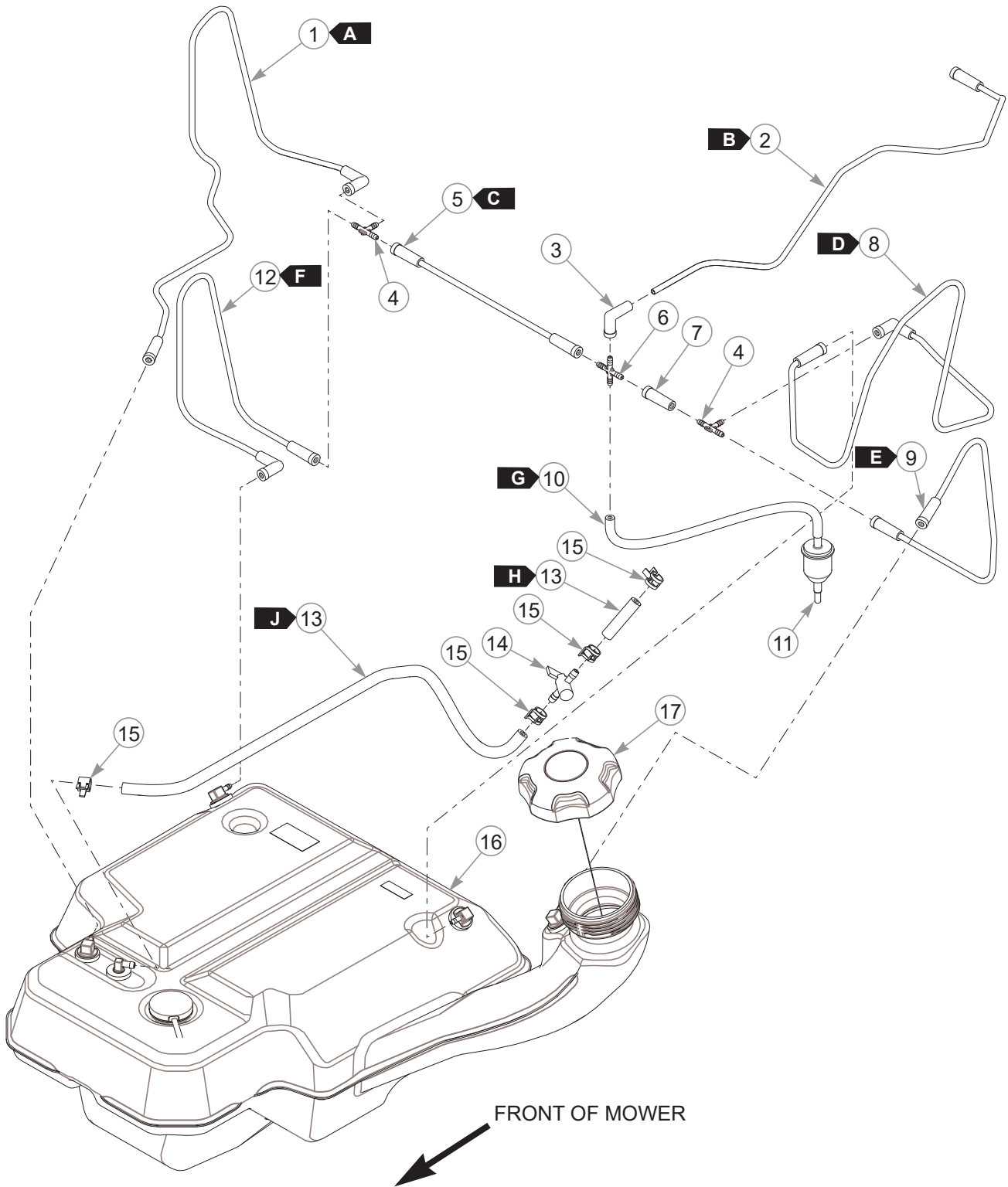

Fuel System

INDEX NO.	PART NO.	QTY.	DESCRIPTION
1	605491	1	3/16" FORMED VAPOR LINE
2	605493	1	3/16" FORMED VAPOR LINE
3	605565	1	3/16" ELBOW BOOT
4	605690	2	3/16" PLASTIC TEE
5	605535	1	3/16" FORMED VAPOR LINE
6	605425	1	3/16" PLASTIC CROSS
7	605564	1	3/16" TO 3/16" STRAIGHT BOOT
8	605534	1	3/16" FORMED VAPOR LINE
9	605492	1	3/16" FORMED VAPOR LINE
10	603326	31 cm	3/16" VAPOR LINE
11	604323	1	VAPOR SYSTEM FILTER
12	605533	1	3/16" FORMED VAPOR LINE
13	015818	61 cm	1/4" FUEL LINE
14	605601	1	INLINE FUEL SHUT-OFF VALVE
15	000323	4	HOSE CLAMP
16	606581	1	FUEL TANK
17	603807	1	RATCHETING GAS CAP, 3.5"

NOTES:

FUEL & VAPOR LINE LENGTHS		
A	—	FRONT RIGHT SIDE PORT TO TEE (VAPOR)
B	—	ENGINE TO CROSS (VAPOR)
C	—	TEE TO CROSS (VAPOR)
D	—	LEFT BACK PORT TO TEE (VAPOR)
E	—	FILLER NECK PORT TO TEE (VAPOR)
F	—	RIGHT BACK PORT TO TEE (VAPOR)
G	31 cm	CROSS TO FILTER (VAPOR)
H	5 cm	VALVE TO ENGINE (FUEL)
J	56 cm	TANK TO VALVE (FUEL)

Fuel System

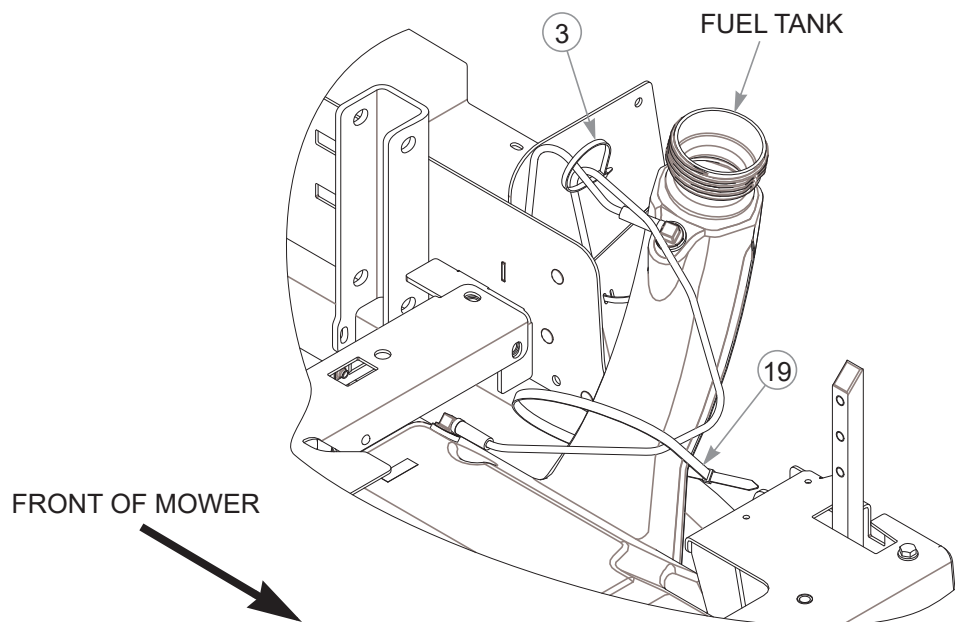
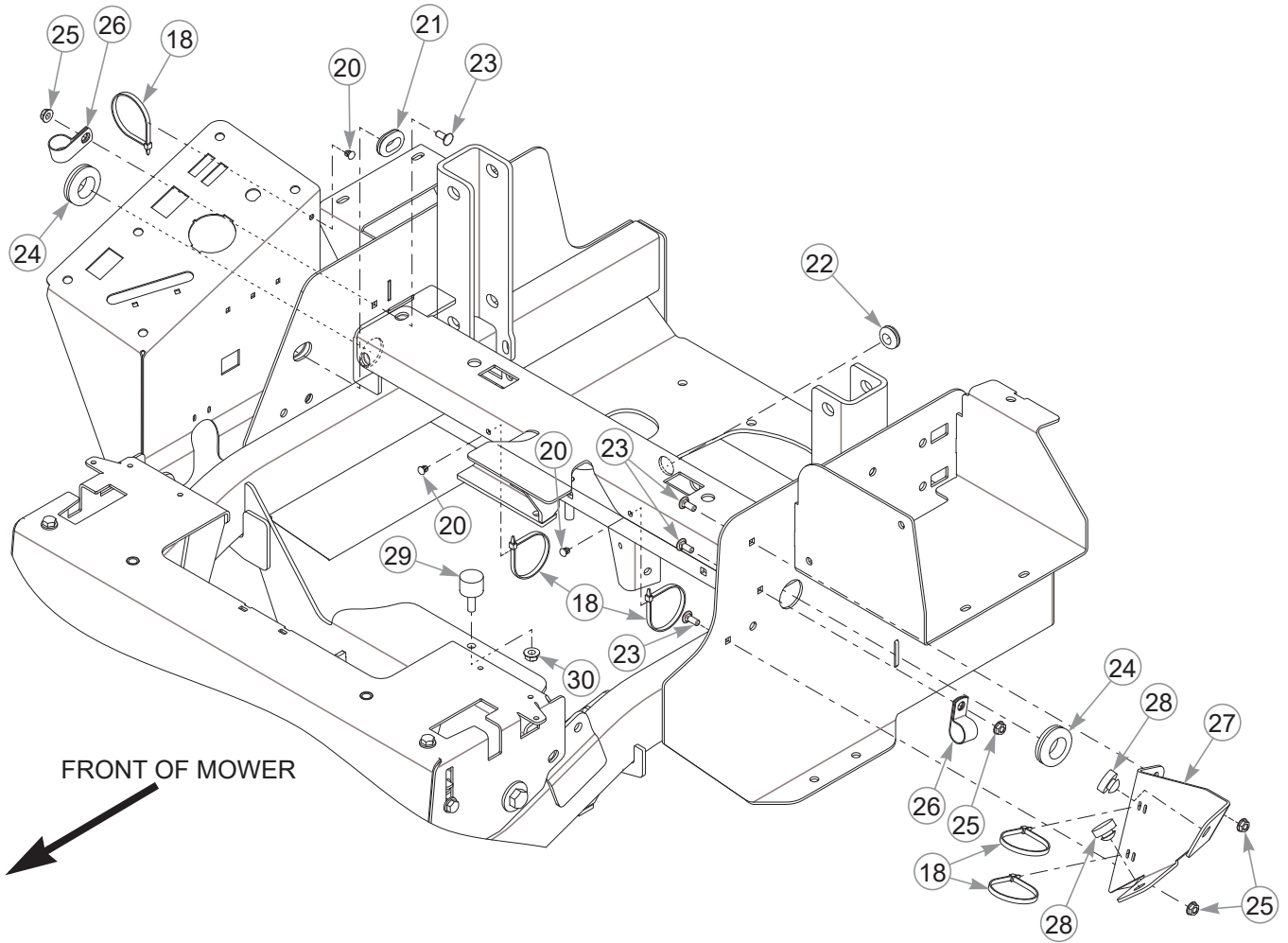

Fuel System

INDEX NO.	PART NO.	QTY.	DESCRIPTION
18	000331	8	WIRE TIE
19	602725	1	WIRE TIE
20	604307	3	PUSH BUTTON MOUNT
21	047456	1	GM .750 X .188 X 1.00 X .12
22	080358	1	GM .50 X 1.00 X .75 X .12
23	601503	4	CB .250-20 X .625 ZNYC
24	706531	2	GM 1.12 X 1.75 X 1.37 X .12
25	016816	4	NT .250-20 HX FL LK ZNY
26	043570	2	LOOP CLAMP
27	124348-1	1	FUEL TANK NECK SUPPORT
28	781880	2	BUMPER
29	605542	1	ISOLATOR
30	016832	1	NT .312-18 HX FLK ZNYC
31	000430	1	WIRE TIE (NOT SHOWN)

NOTES:

Section 6

Battery & Fenders	6-2
Instrument Panel	6-4

Battery & Fenders

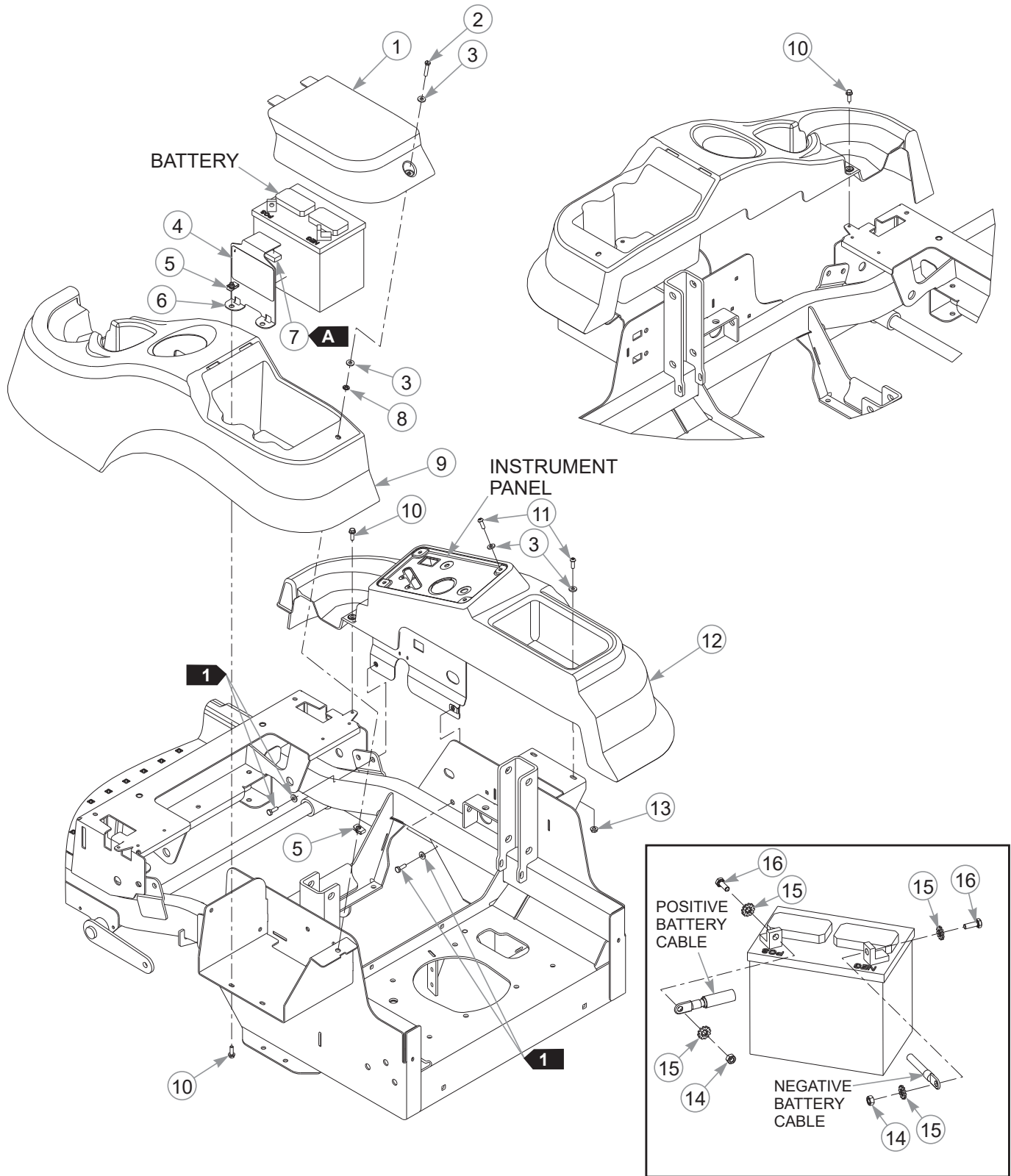

Battery & Fenders

INDEX NO.	PART NO.	QTY.	DESCRIPTION
1	605558	1	LS FENDER LID
2	605627	1	CS .250-20 X 1.25 HX
3	605628	8	FW .281 X .625 X .066
4	601815	1	BATTERY WARNINGS DECAL
5	601982	3	CN .250-20 X .15 MAX THK
6	552858	1	BATTERY HOLD DOWN (WITH SEAL & DECAL)
7	713198	6 cm	SEAL 3/8 X 3/4
8	605629	1	UNTHREADED PN .250 ID
9	605522	1	LS FENDER
10	604324	4	CS .250-20 X .75 HX FLG
11	605473	6	CS .25-20 BH TX BZ
12	605521	1	RS FENDER
13	016816	2	NT .250-20 HX FL LK ZNY
14	024927	2	NT .250-20 HX G5
15	029868	4	LW .250 INT-EXT TOOTH Z
16	055939	2	CS .250-20 X .75 HX G5

NOTES:

SEAL LENGTH	
	6 cm

1. Part of the Instrument Panel assembly.
2. When performing service on the mower, disconnect the negative battery cable (black) and do not reconnect it to the battery until ready to start the engine.

Instrument Panel

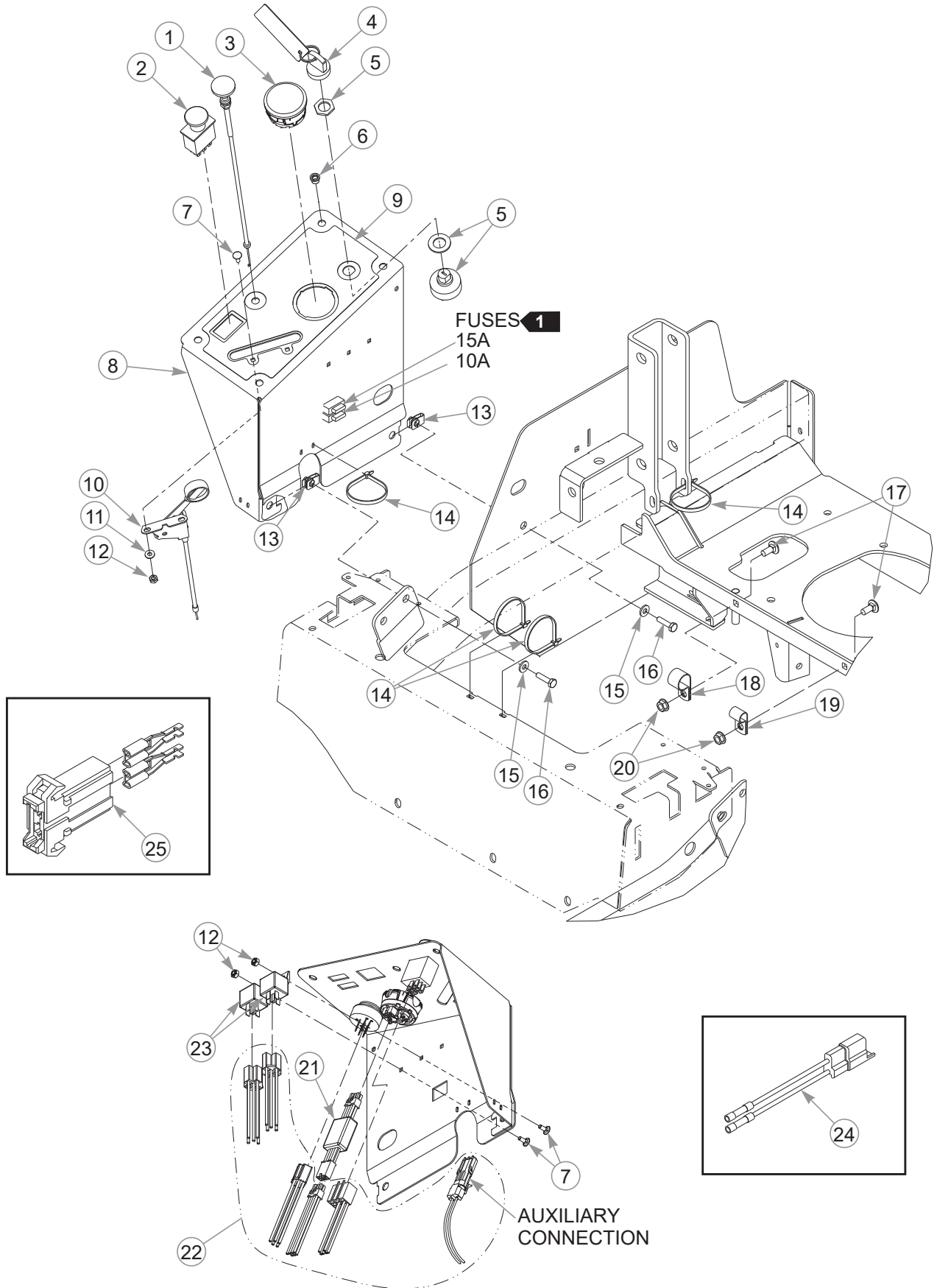

Instrument Panel

INDEX NO.	PART NO.	QTY.	DESCRIPTION
1	786657	1	CHOKE CABLE
2	776476	1	PTO SWITCH
3	605483	1	FUEL GAUGE/HOUR METER
4	785808	1	KEY ASSEMBLY
5	045898	1	IGNITION SWITCH
6	808477	4	1/4-20 THREAD RIVET NUT
7	601098	4	CB 10-24 X .500 ZYNC
8	552854	1	INSTRUMENT PANEL (WITH DECAL)
9	605604	1	INSTRUMENT PANEL DECAL
10	778365	1	THROTTLE CABLE
11	704932	2	FW .219 X .500 X .048
12	059832	4	NT #10-24 HX NL ZN
13	601982	2	CN .250-20 X .15 MAX THK
14	000331	6	WIRE TIE
15	768515	2	FW .281 X .625 X .066
16	056077	2	CS .250-20 X 1.00 HX G5
17	016253	2	CB .312-18 X .75 FUL ZN
18	043570	1	LOOP CLAMP
19	000398	1	LOOP CLAMP
20	016832	2	NT .312-18 HX FLK ZNYC
21	605554	1	WIRE HARNESS ADAPTER
22	605457	1	WIRE HARNESS
23	601053	2	SEALED RELAY (WITH BRACKET)
24	114052	1	CLUTCH CONNECTOR REPAIR KIT
25	601047	1	FUSE HOLDER

NOTES:

1. Part of the wire harness.

Section 7

48" Side Discharge Service Deck	7-2
48" Side Discharge Deck Pulleys & Spindles	7-4
48" Side Discharge Deck	7-6
54" Service Deck	7-8
54" Deck Pulleys & Spindles	7-10
54" Deck	7-12
48" Rear Discharge Service Deck	7-14
48" Rear Discharge Deck Pulleys & Spindles	7-16
48" Rear Discharge Deck	7-18
Rear Discharge Debris Shield	7-20
Deck Lift.	7-22

48" Side Discharge Service Deck

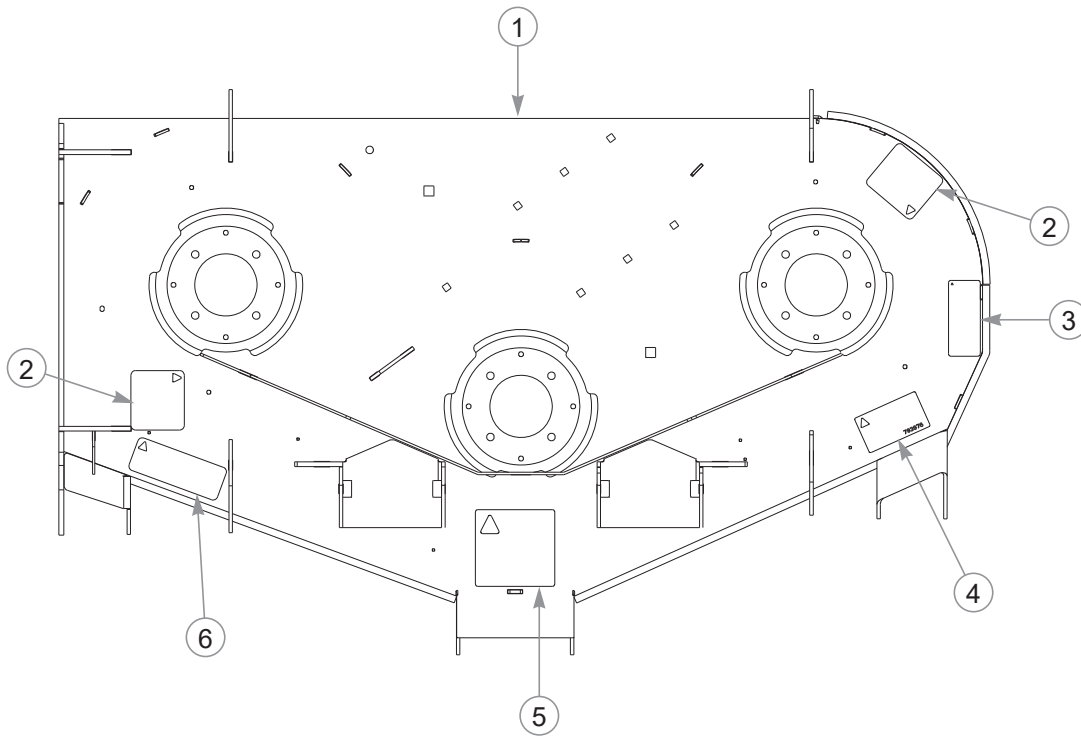

INDEX NO.	PART NO.	QTY.	DESCRIPTION
1	552872	1	48" DECK (WITH DECALS)
2	601837	2	DECK DANGERS DECAL
3	601892	1	THROWN OBJECTS DECAL
4	793976	1	48" DECK ID DECAL
5	781419	1	BELT ROUTING DECAL
6	601624	1	DISCHARGE CHUTE DECAL

NOTES:

This page intentionally left blank.

48" Side Discharge Deck Pulleys & Spindles

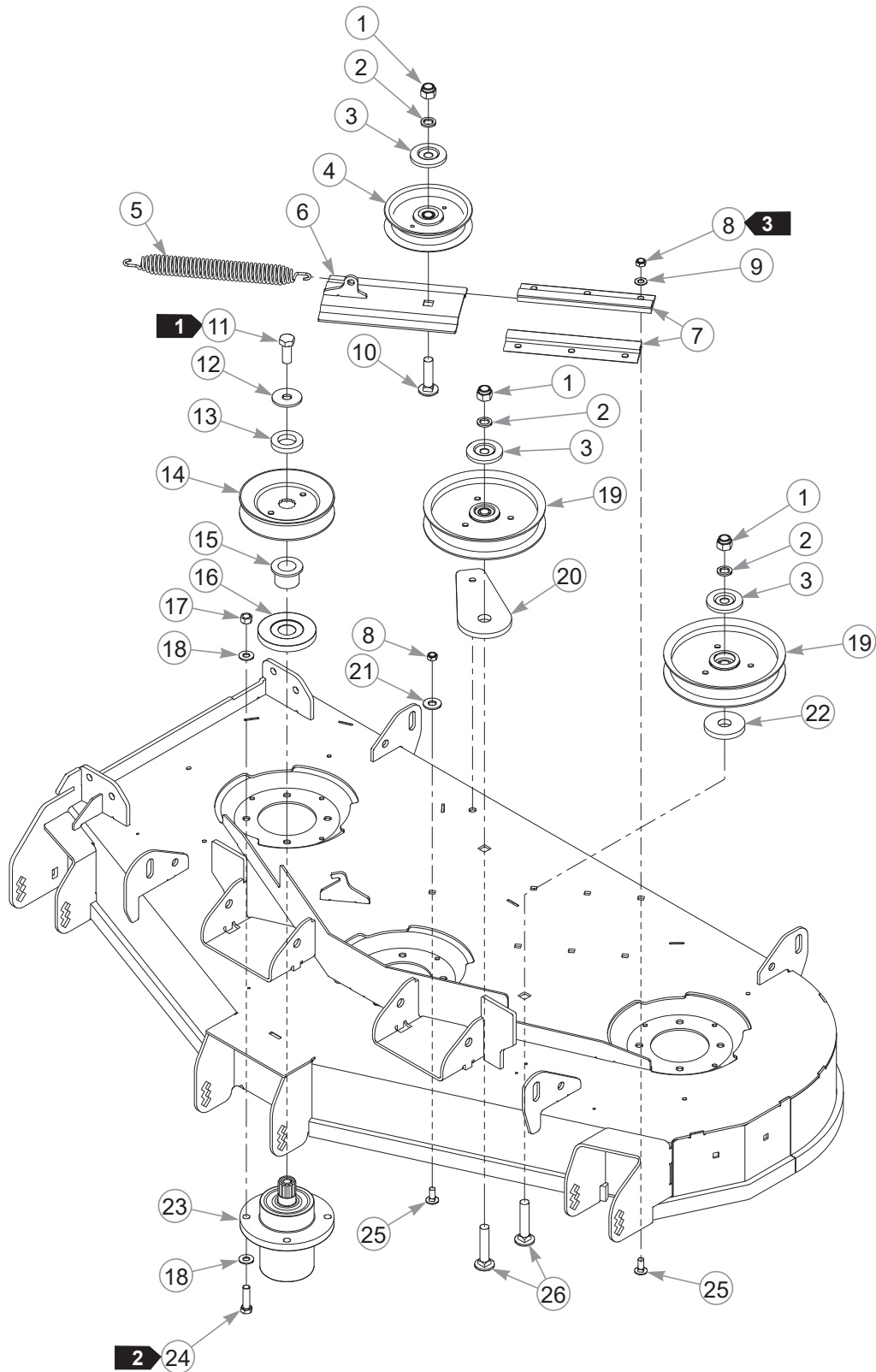

48" Side Discharge Deck Pulleys & Spindles

INDEX NO.	PART NO.	QTY.	DESCRIPTION
1	781567	3	NT .500-13 HX G8 ZY NL
2	604486	3	FW .531 X .812 X .089 HD
3	605467	3	DUST SHIELD
4	605512	1	4" IDLER PULLEY
5	122388	1	IDLER SPRING
6	121052	1	TENSIONER SLED
7	604790	2	IDLER SLIDE
8	604251	7	NT .312-18 HX NL JAM G2 ZN
9	604252	6	FW .340 X .675 X .035 ZN
10	604253	1	CB .50-13 X 2.00 STD ZN
11	705954	3	CS .500-13 X 1.25 HX G5
12	798603	3	FW .515 X 1.65 X .125 HD ZY
13	604777	3	SPINDLE SPACER
14	604665	3	DRIVE PULLEY B-SEC
15	605504	3	PULLEY SPACER
16	606362	3	DUST SHIELD
17	054502	12	NT .375-16 HX G5 ZNY
18	767954	24	FW .379 X .813 X .063
19	605463	2	6.00" IDLER PULLEY
20	605465	1	IDLER PULLEY MOUNT BASE
21	017129	1	FW .440 X 1.00 X .083 ZNY
22	605508	1	FW .73 X 2.25 X .312
23	605380	3	SPINDLE ASSEMBLY
24	005116	12	CS .375-16 X 1.375 HX G5
25	016253	7	CB .312-18 X .75 FUL ZN
26	604254	2	CB .50-13 X 2.50 STD ZN

NOTES:

1. Torque to 99 N•m.
2. Torque to 41 N•m.
3. Torque to 4–8 N•m.

48" Side Discharge Deck

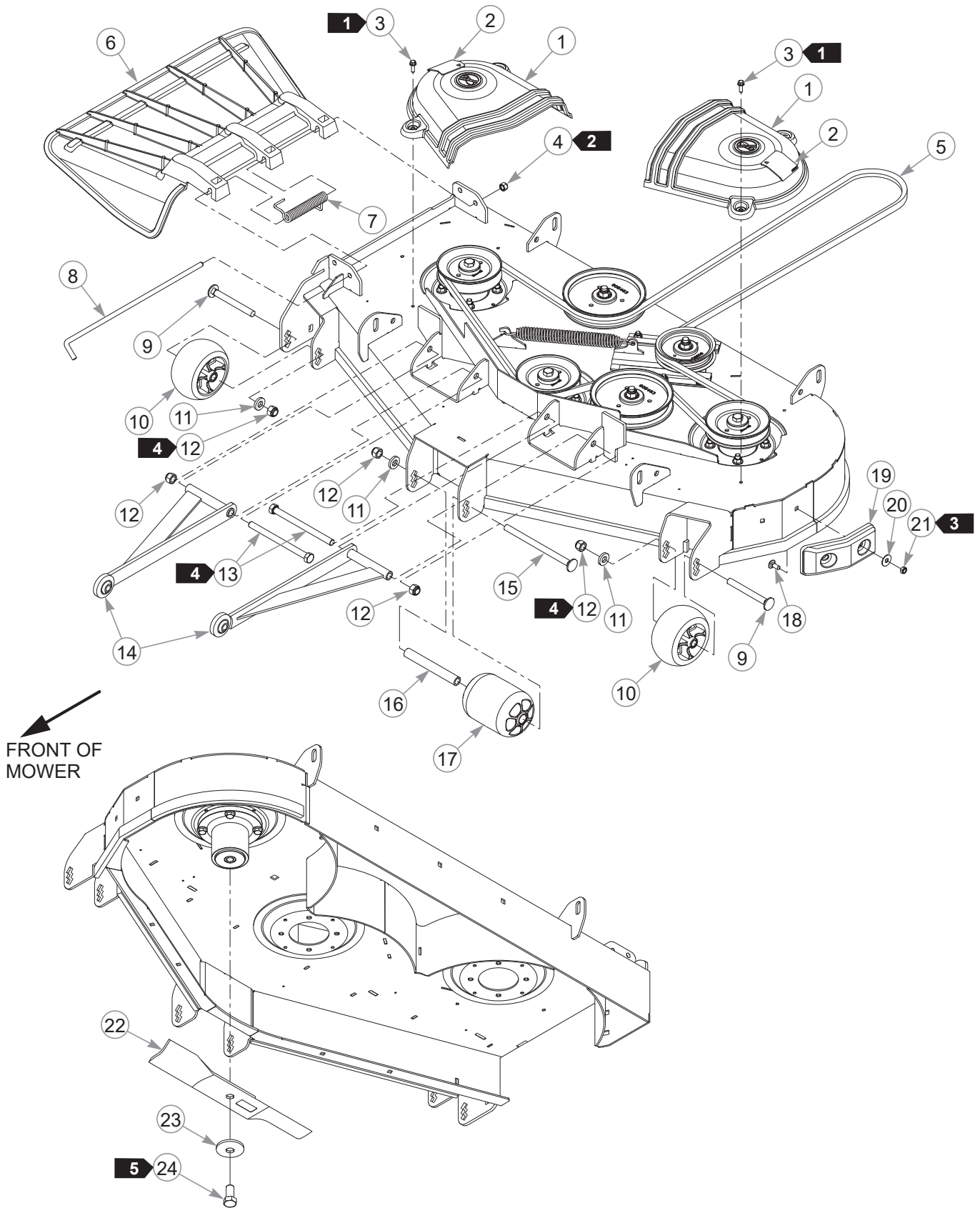

48" Side Discharge Deck

INDEX NO.	PART NO.	QTY.	DESCRIPTION
1	553531	2	PULLEY COVER (WITH DECAL)
2	602562	2	NO SERVICE DECAL
3	604324	4	CS .250-20 X .75 HX FLG
4	086660	1	NT .375-16 HX G5 ZY NL
5	791335	1	BELT, B 143" EL
6	605469	1	DISCHARGE CHUTE
7	602435	1	TORSION SPRING
8	602432	1	CHUTE PIN
9	602339	2	CB .500-13 X 4.50 STD ZN
10	604780	2	ANTI-SCALP WHEEL
11	767962	3	FW .531 X 1.063 X .175
12	781567	5	NT .500-13 HX G8 ZY NL
13	042630	2	CS .500-13 X 6.50 HX G5 Z
14	113717	2	PULLER
15	602338	1	CB .500-13 X 7.50 STD ZN
16	602344	1	SPACER 5.73
17	602341	1	PLASTIC WHEEL
18	016253	2	CB .312-18 X .75 FUL ZN
19	605376	1	DECK BUMPER
20	079210	2	FW .344 X 1.00 X .06 ZNYC
21	604251	2	NT .312-18 HX NL JAM G2 ZN
22	606252	3	BLADE, 16.5"-H-F-CW
	601014	3	BLADE, F16.50"-L-F-CW
	601123	3	BLADE, 16.5"-L-F-CW
	796631	3	BLADE, 16.5"-GAT-F-CW
	796623	3	BLADE, 16.5"-MUL-F-CW
23	782474	3	CW .631 X 2.25 X .187 PNT
24	781872	3	CS .625-11 X 1.25 HX G5 Z

NOTES:

1. Torque to 2.7–6.8 N•m on these self-tapping screws.
2. Do not torque; the discharge chute must pivot freely.
3. Torque to 4–8 N•m.
4. Torque to 5–9 N•m.
5. Torque to 160 N•m.

54" Service Deck

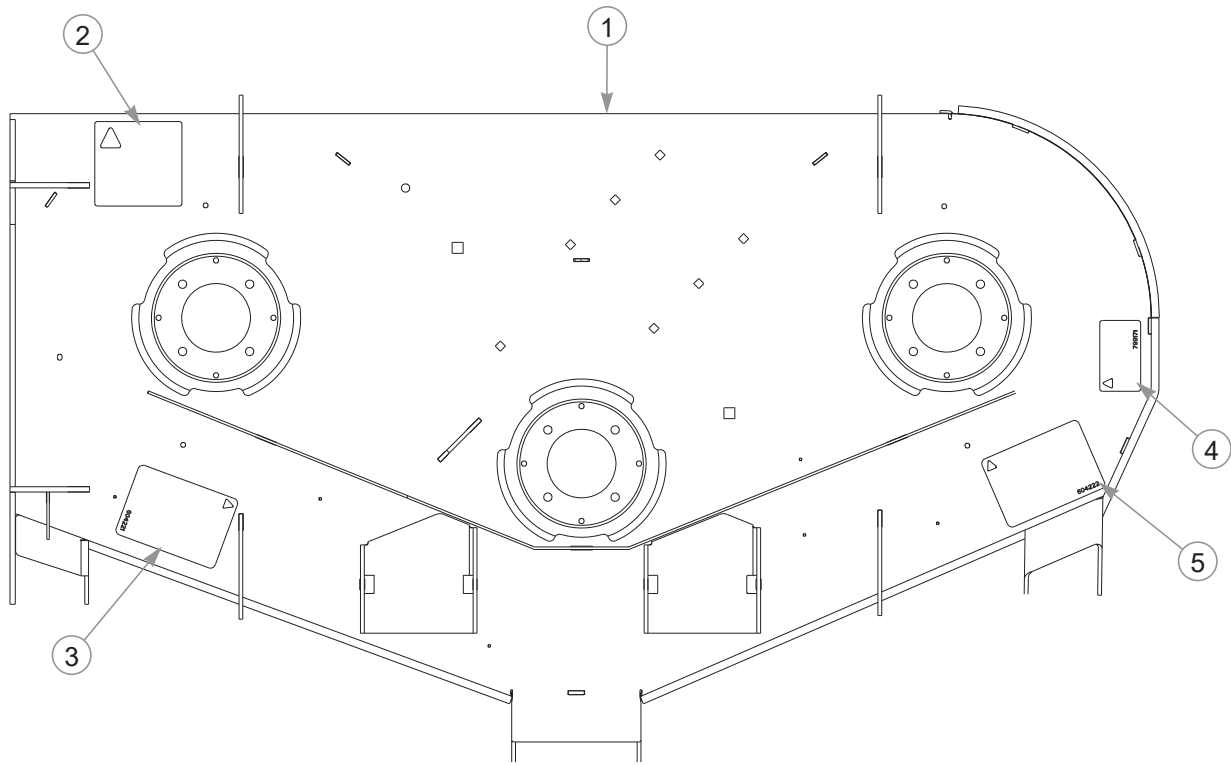

INDEX NO.	PART NO.	QTY.	DESCRIPTION
1	552873	1	54" DECK (WITH DECALS)
2	781419	1	BELT ROUTING DECAL
3	604221	1	DANGER/CHUTE DECAL
4	799171	1	54" DECK ID DECAL
5	604222	1	DANGER/OBJECTS DECAL

NOTES:

This page intentionally left blank.

54" Deck Pulleys & Spindles

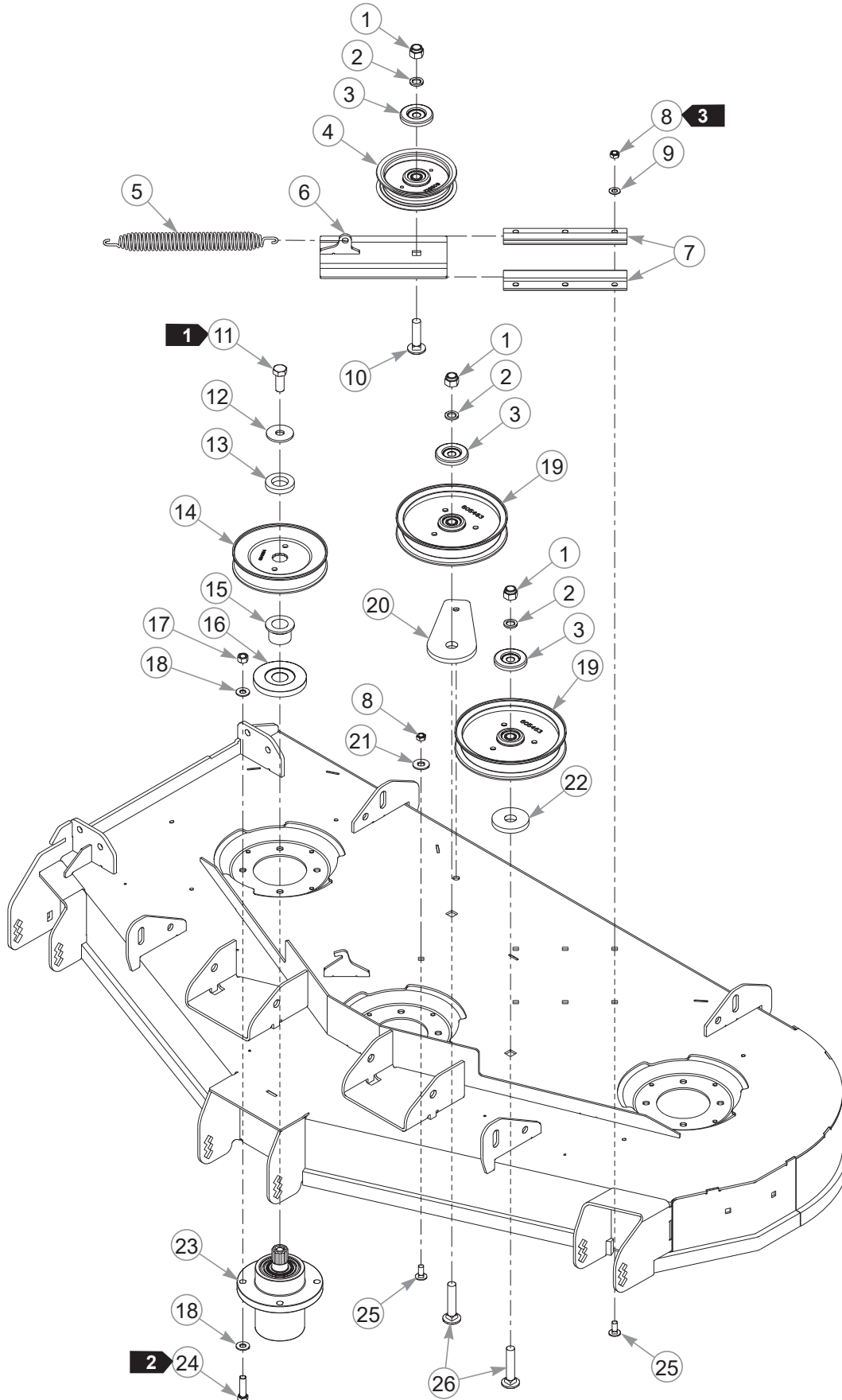

54" Deck Pulleys & Spindles

INDEX NO.	PART NO.	QTY.	DESCRIPTION
1	781567	3	NT .500-13 HX G8 ZY NL
2	604486	3	FW .531 X .812 X .089 HD
3	605467	3	DUST SHIELD
4	605512	1	4" IDLER PULLEY
5	122388	1	IDLER SPRING
6	121052	1	TENSIONER SLED
7	604790	2	IDLER SLIDE
8	604251	7	NT .312-18 HX NL JAM G2 ZN
9	604252	6	FW .340 X .675 X .035 ZN
10	604253	1	CB .50-13 X 2.00 STD ZN
11	705954	3	CS .500-13 X 1.25 HX G5
12	798603	3	FW .515 X 1.65 X .125 HD ZY
13	604777	3	SPINDLE SPACER
14	604664	3	PULLEY, DECK DRIVE B-SEC
15	605504	3	PULLEY SPACER
16	606362	3	DUST SHIELD
17	054502	12	NT .375-16 HX G5 ZNY
18	767954	24	FW .379 X .813 X .063
19	605463	2	6.00" IDLER PULLEY
20	605465	1	IDLER PULLEY MOUNT BASE
21	017129	1	FW .440 X 1.00 X .083 ZNY
22	605508	1	FW .73 X 2.25 X .312
23	605380	3	SPINDLE ASSEMBLY
24	005116	12	CS .375-16 X 1.375 HX G5
25	016253	7	CB .312-18 X .75 FUL ZN
26	604254	2	CB .50-13 X 2.50 STD ZN

NOTES:

1. Torque to 99 N•m.
2. Torque to 41 N•m.
3. Torque to 4–8 N•m.

54" Deck

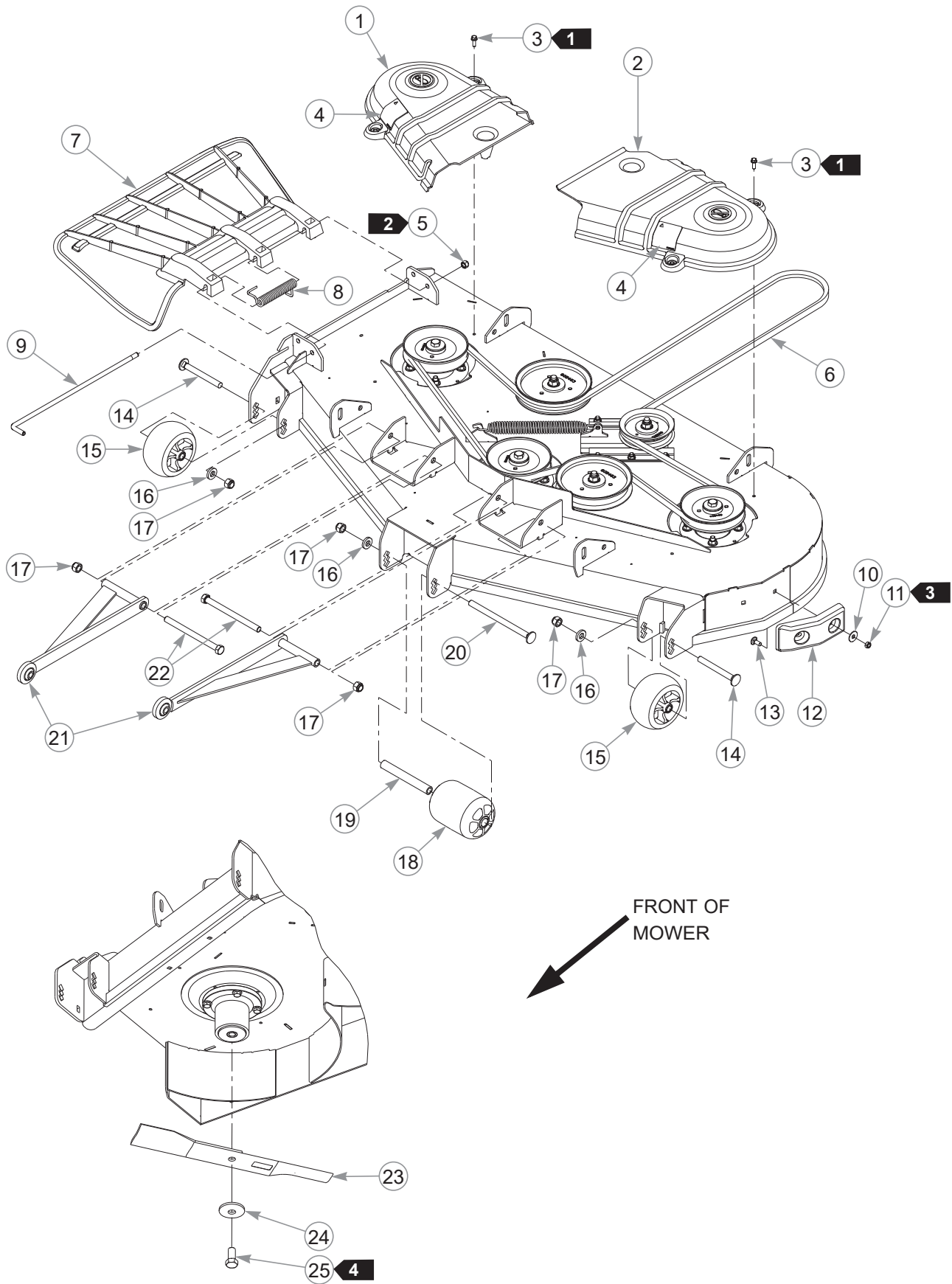

54" Deck

INDEX NO.	PART NO.	QTY.	DESCRIPTION
1	553064	1	RS PULLEY COVER (WITH DECAL)
2	553065	1	LS PULLEY COVER (WITH DECAL)
3	604324	4	CS .250-20 X .75 HX FLG
4	602562	2	NO SERVICE DECAL
5	086660	1	NT .375-16 HX G5 ZY NL
6	786483	1	BELT B 148.56" EL
7	605469	1	DISCHARGE CHUTE
8	602435	1	TORSION SPRING
9	602432	1	CHUTE PIN
10	079210	2	FW .344 X 1.00 X .06 ZNYC
11	604251	2	NT .312-18 HX NL JAM G2 ZN
12	605376	1	DECK BUMPER
13	016253	2	CB .312-18 X .75 FUL ZN
14	602339	2	CB .500-13 X 4.50 STD ZN
15	604780	2	ANTI-SCALP WHEEL
16	767962	3	FW .531 X 1.063 X .175
17	781567	5	NT .500-13 HX G8 ZY NL
18	602341	1	PLASTIC WHEEL
19	602344	1	SPACER 5.73
20	602338	1	CB .500-13 X 7.50 STD ZN
21	113717	2	PULLER
22	042630	2	CS .500-13 X 6.50 HX G5 Z
23	606251	3	BLADE, 18.50"-H-F-CW
	601012	3	BLADE F18.50"-L-F-CW
	601124	3	BLADE, 18.50"-L-F-CW
	797704	3	BLADE, 18.50"-MUL-F-CW
	797712	3	BLADE, 18.50"-GAT-F-CW
24	782474	3	CW .631 X 2.25 X .187 PNT
25	781872	3	CS .625-11 X 1.25 HX G5 Z

NOTES:

1. Torque to 3–6 N•m on these self-tapping screws.
2. Do not torque; the discharge chute must pivot freely.
3. Torque to 4–8 N•m.
4. Torque to 160 N•m.

48" Rear Discharge Service Deck

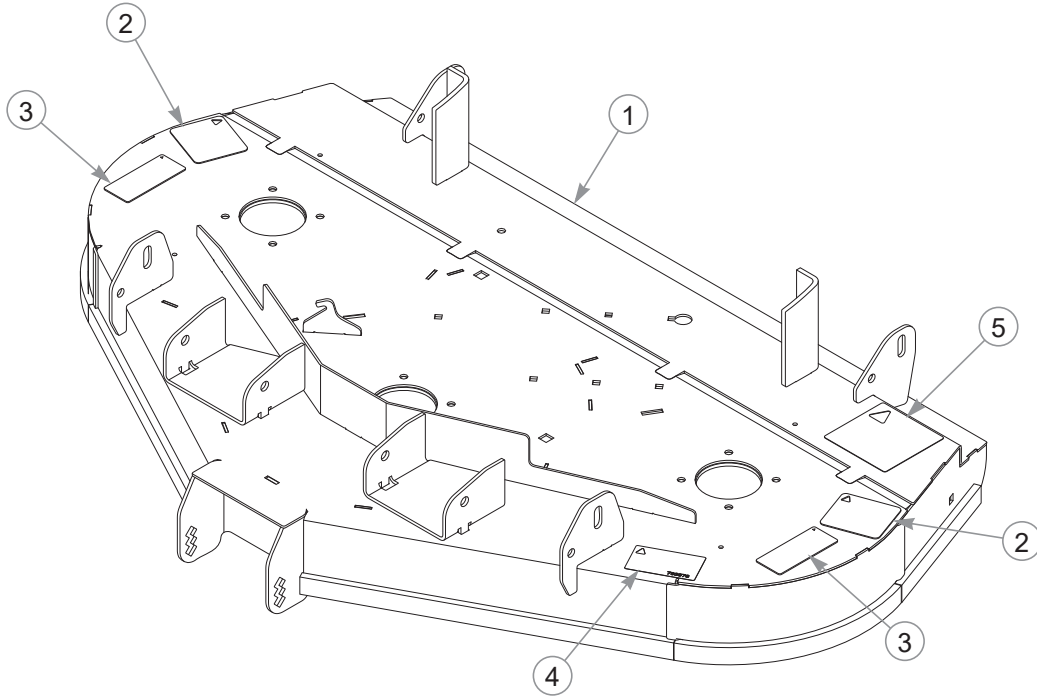

INDEX NO.	PART NO.	QTY.	DESCRIPTION
1	553017	1	DECK 48" FST RD (WITH DECALS)
2	601837	2	DECK DANGERS DECAL
3	601892	2	THROWN OBJECTS DECAL
4	793976	1	48" DECK ID DECAL
5	781419	1	BELT ROUTING DECAL

NOTES:

This page intentionally left blank.

48" Rear Discharge Deck Pulleys & Spindles

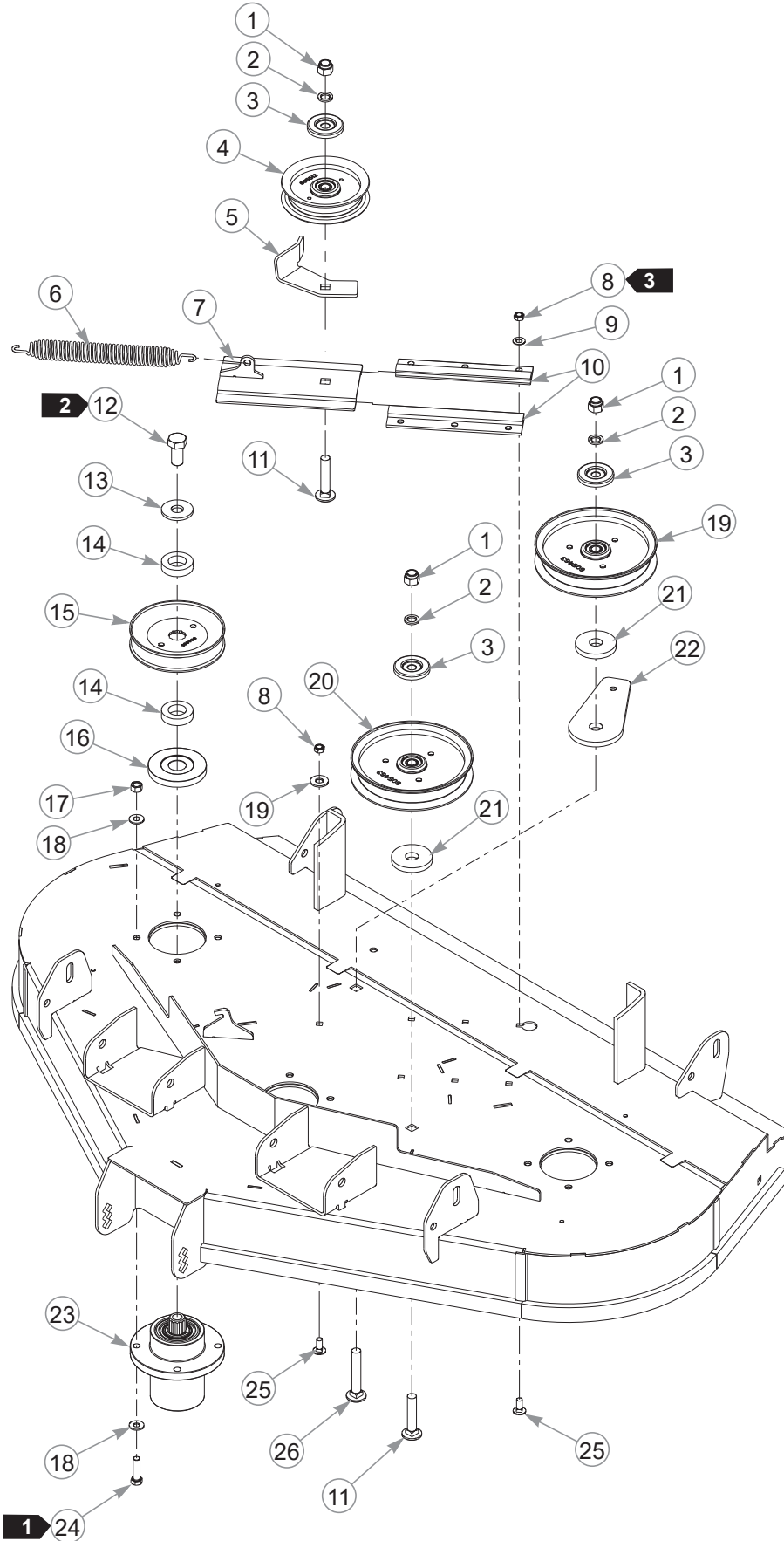

48" Rear Discharge Deck Pulleys & Spindles

INDEX NO.	PART NO.	QTY.	DESCRIPTION
1	781567	3	NT .500-13 NL
2	604486	3	FW .531 X .812 X .089 HD
3	605467	3	DUST SHIELD
4	605512	1	4" IDLER PULLEY
5	124488-4	1	BELT GUIDE
6	122388	1	IDLER SPRING
7	121052	1	TENSIONER SLED
8	604251	7	NT .312-18 HX NL JAM G2 ZN
9	604252	6	FW .340 X .675 X .035 ZN
10	604790	2	IDLER SLIDE
11	604254	2	CB .50-13 X 2.50 STD ZN
12	781872	3	CS .625-11 X 1.25 HX G5
13	017152	3	FW .688 X 1.75 X .16 HD
14	604661	6	PULLEY SPACER
15	604665	3	DRIVE PULLEY B-SEC
16	606362	3	DUST SHIELD
17	054502	12	NT .375-16 HX G5
18	767954	24	FW .379 X .813 X .063
19	017129	1	FW .440 X 1.00 X .083 ZNY
20	605463	2	6.00" IDLER PULLEY
21	605508	2	FW .73 X 2.25 X .312
22	605465	1	IDLER PULLEY MOUNT BASE
23	783506	3	BLADE SPINDLE
24	005116	12	CS .375-16 X 1.375 HX G5
25	016253	7	CB .312-18 X .75 FUL ZN
26	021980	1	CB .500-13 X 3.00 STD Z

NOTES:

1. Torque to 41 N•m.
2. Torque to 160 N•m.
3. Torque to 4–8 N•m.

48" Rear Discharge Deck

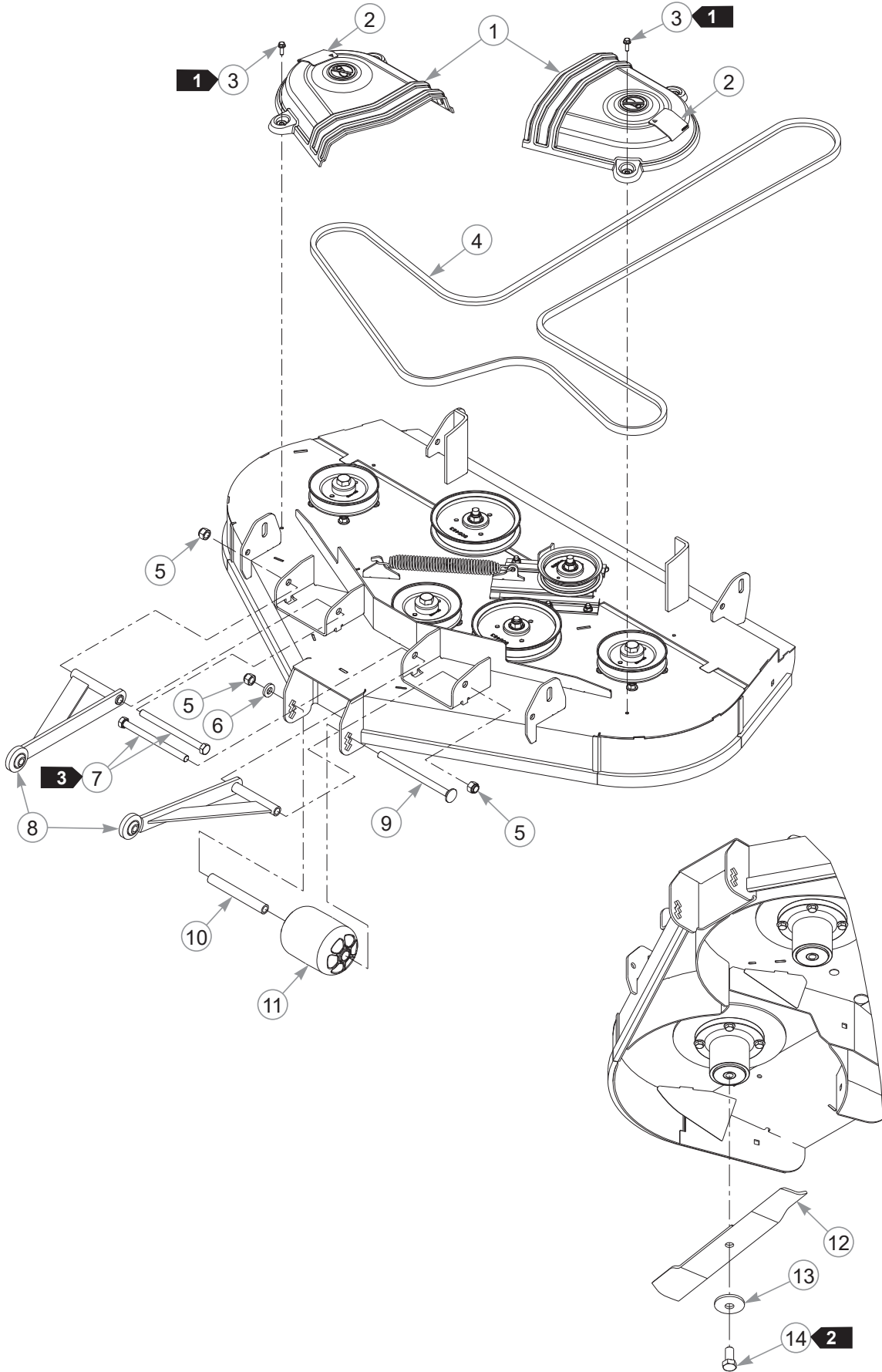

48" Rear Discharge Deck

INDEX NO.	PART NO.	QTY	DESCRIPTION
1	553531	2	PULLEY COVER (WITH DECAL)
2	602562	2	NO SERVICE DECAL
3	604324	4	CS .250-20 X .75 HX FLG
4	605507	1	BELT, B-SECTION 54"
5	781567	3	NT .500-13 HX G8 ZY NL
6	767962	1	FW .531 X 1.063 X .175
7	042630	2	CS .500-13 X 6.50 HX G5 Z
8	109434	2	PULLER
9	602338	1	CB .500-13 X 7.50 STD ZN
10	602344	1	SPACER
11	602341	1	PLASTIC WHEEL
12	601123	3	BLADE, 16.50"-L-F-CW
	601014	3	BLADE, F16.50"-L-F-CW
	796623	3	BLADE, 16.50"-MUL-F-CW
	796631	3	BLADE, 16.50"-GAT-F-CW
13	782474	3	CW .631 X 2.25 X .187 PNT
14	781872	3	CS .625-11 X 1.25 HX G5 Z

NOTES:

1. Torque to 2.7–6.8 N•m on these self-tapping screws.
2. Torque to 160 N•m.
3. Tighten to 5.4–9.5 N•m to remove play on the cap screw.

Rear Discharge Debris Shield

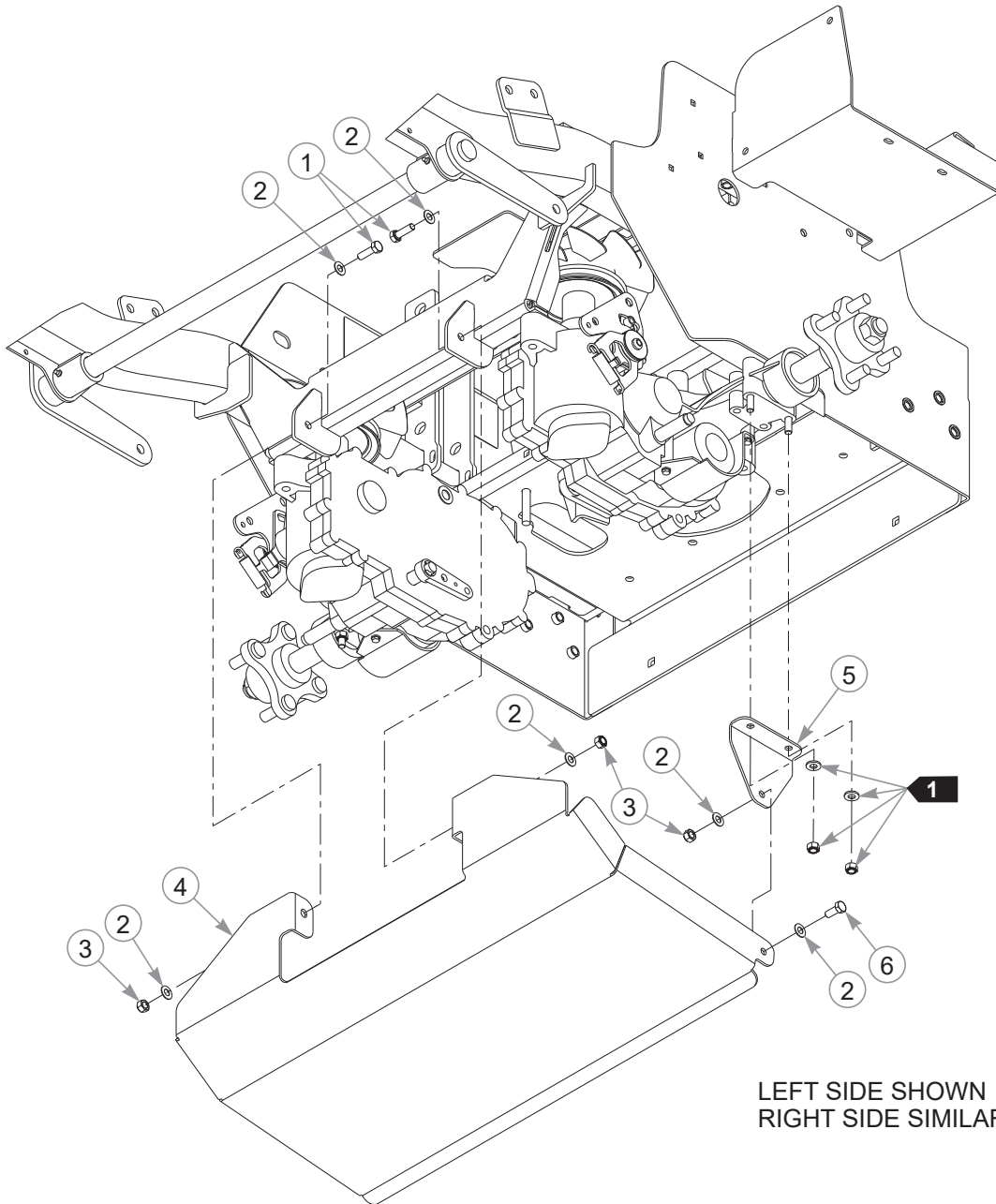

LEFT SIDE SHOWN
RIGHT SIDE SIMILAR

Rear Discharge Debris Shield

INDEX NO.	PART NO.	QTY.	DESCRIPTION
1	036236	2	CS .312-18 X 1.00 HX G5
2	604252	8	FW .340 X .675 X .035 ZN
3	058776	4	NT .312-18 HX G5 ZY NL
4	122256	1	REAR DISCHARGE SHIELD
5	122297	2	SHIELD MOUNT BRACKET
6	034280	2	CS .312-18 X .75 HX G5

NOTES:

1. Part of the transmission assembly.

Deck Lift

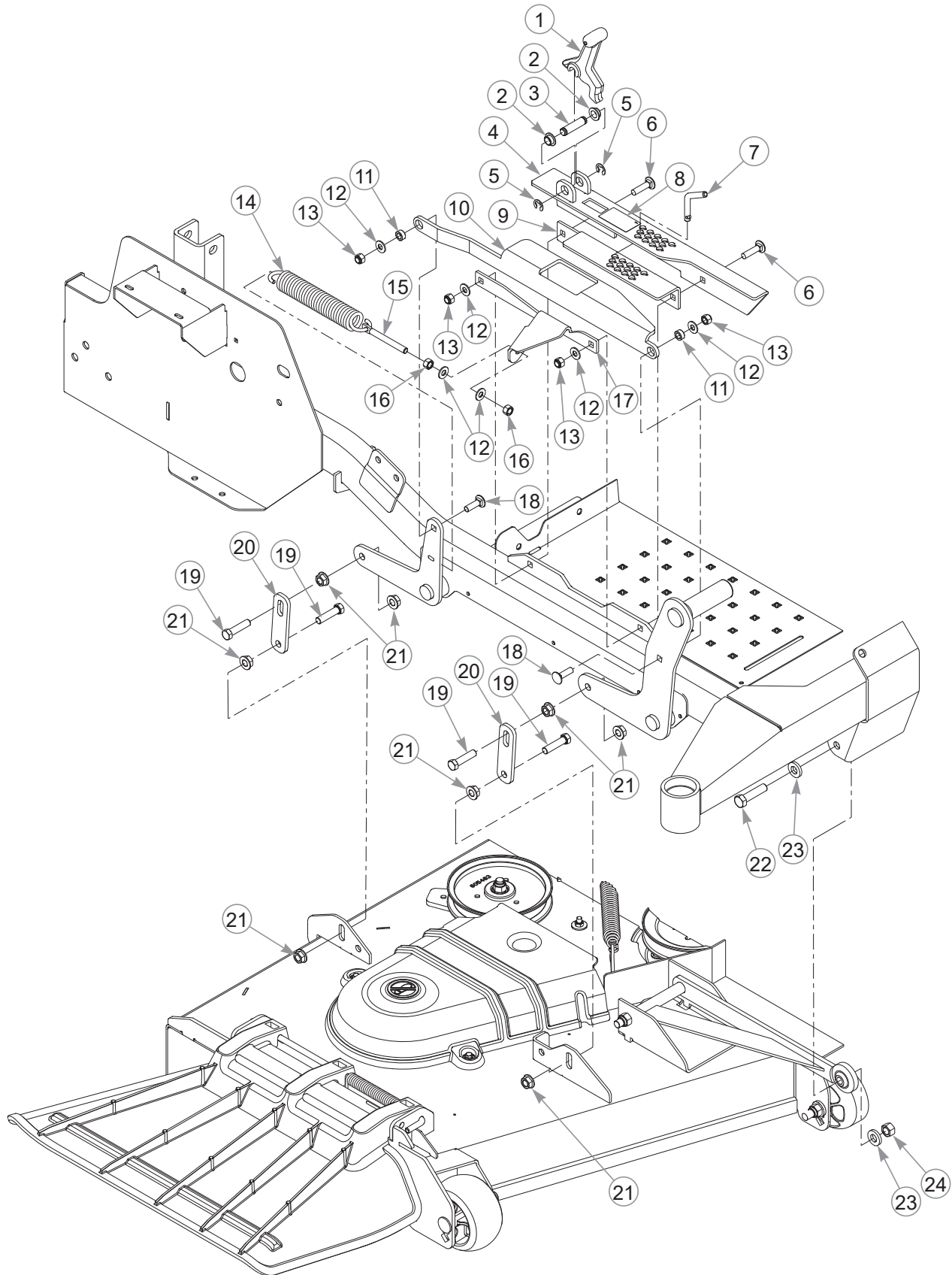

Deck Lift

INDEX NO.	PART NO.	QTY.	DESCRIPTION
1	605466	1	TRANSPORT LATCH
2	768259	2	BUSHING
3	605470	1	CE .500 X 2.00 X 1.63
4	553089	1	INDICATOR PLATE (WITH DECAL)
5	793059	2	E CLIP (1/2") .80 X .396
6	710194	2	CB .375-16 X 1.50 STD G5
7	601963	1	DECK HEIGHT STOP PIN
8	605786	1	DECK HEIGHT DECAL CE
9	119970	1	INNER CUT HEIGHT BRACKET
10	119969	1	INDICATOR BRACKET
11	118900	2	DECK LIFT LINK SPACER
12	767954	6	FW .379 X .813 X .063
13	086660	4	NT 0.375-16 HX G5 ZY NL
14	008938	1	SPRING
15	601486	1	EB .375-16 X 3.00 FULL THD
16	054502	2	NT .375-16 HX G5 ZNY
17	120779	1	SPRING BRACKET
18	603113	2	CB .375-16X1.250 G5 ZNC
19	055749	8	CS .437-14 X 1.75 HX G5
20	124354-1	4	DECK LIFT LINK
21	704643	16	NT .437-14 HX FLG ZN
22	078949	2	CS .500-13 X 2.00 HX G5 ZNY
23	767962	4	FW .531 X 1.063 X .175
24	008193	2	NT .500-13 HX G5 ZNYC

NOTES:

Deck Lift

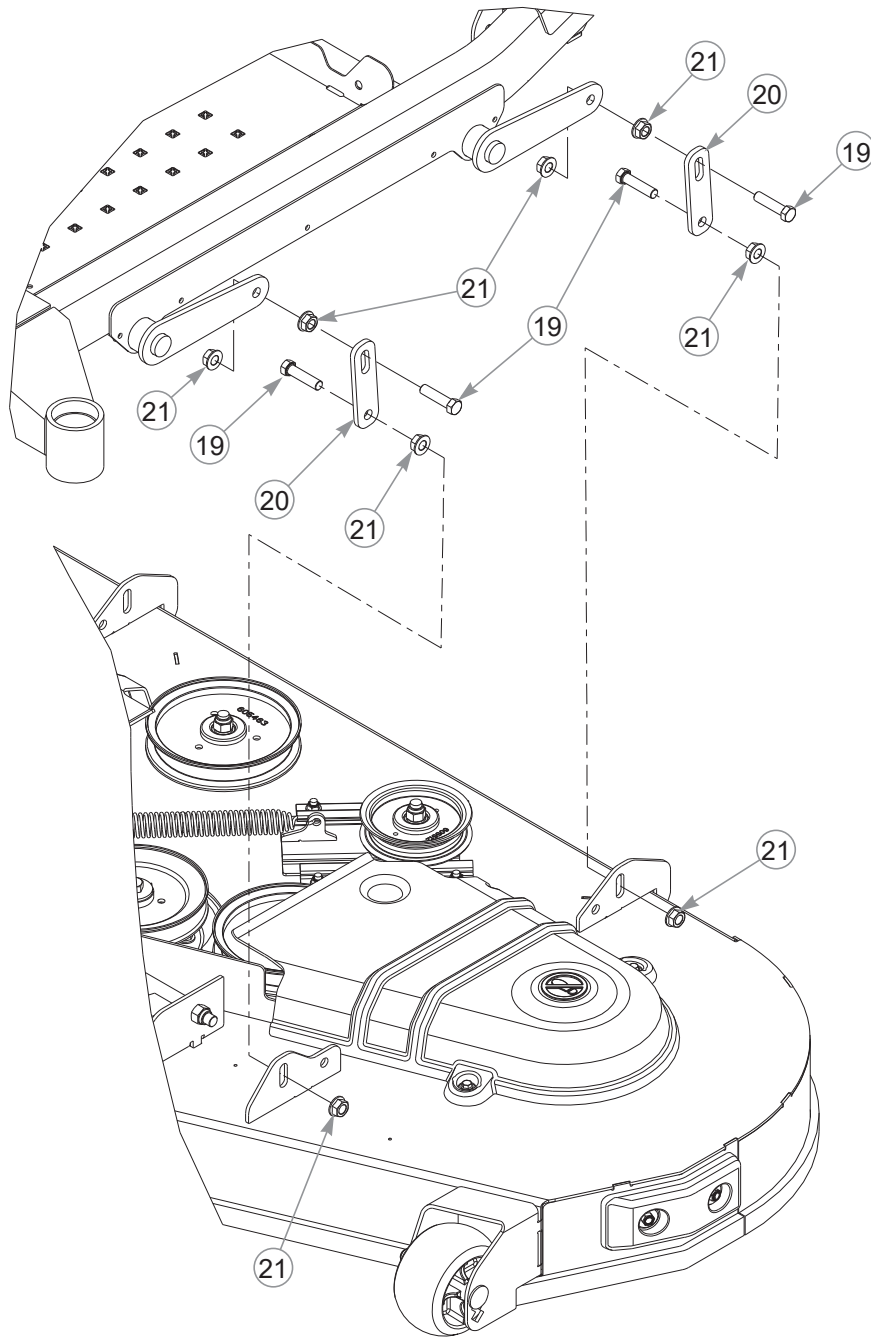

Section 8

Seat & Footrest	8-2
Seat Service Parts	8-4
ROPS	8-6

Seat & Footrest

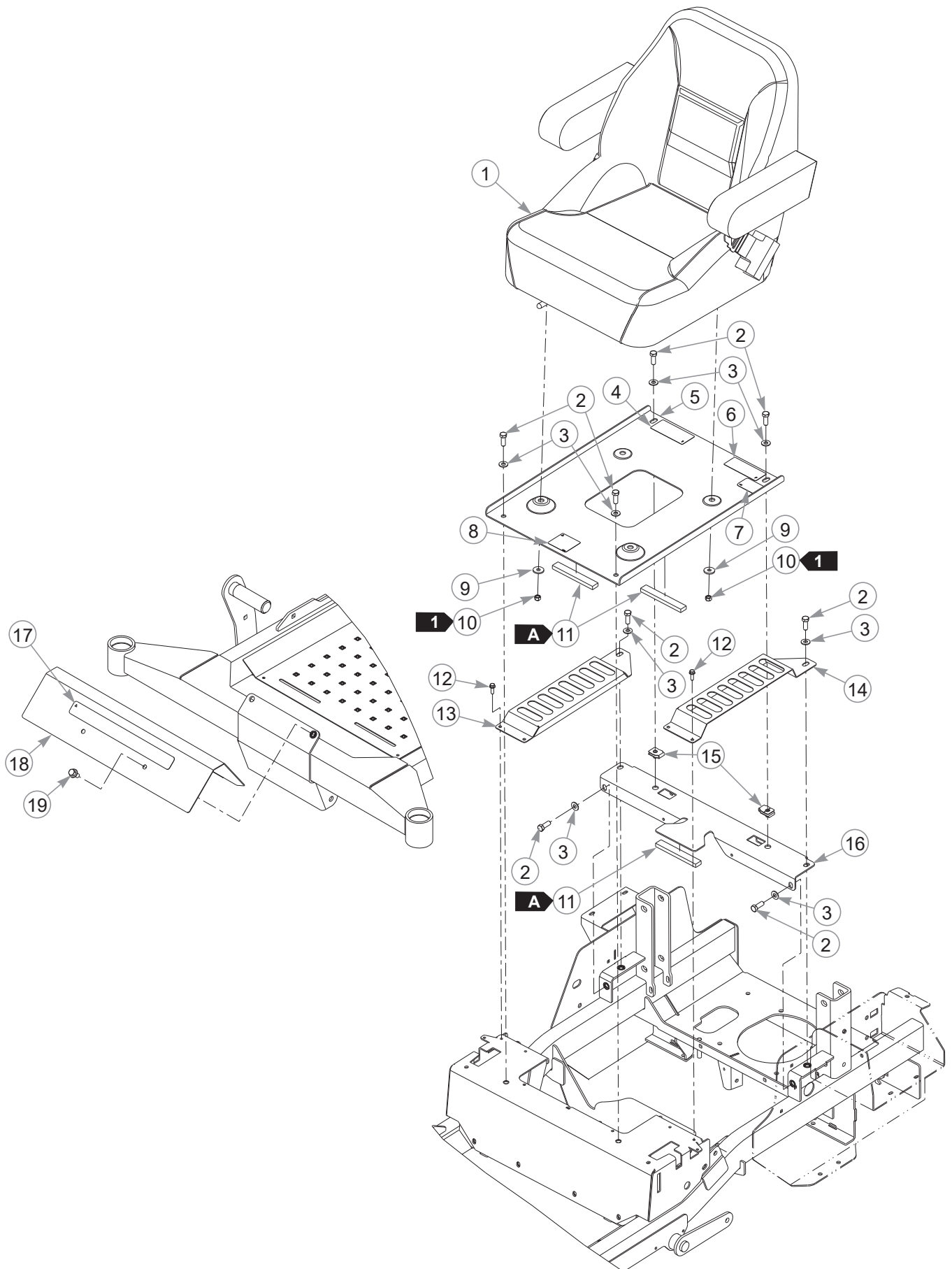

Seat & Footrest

INDEX NO.	PART NO.	QTY.	DESCRIPTION
1	605566	1	TWO-PIECE SEAT
2	036244	8	CS .375-16 X 1.00 HX G5
3	767954	8	FW .379 X .813 X .063
4	601967	1	ENGINE COMPARTMENT DECAL
5	553090	1	SEAT PAN (WITH DECALS)
6	779280	1	HOT DECAL
7	605782	1	FUEL FILL LEVEL DECAL
8	602562	1	NO SERVICE DECAL
9	712927	4	FW .344 X 1.00 X .12 HRD Z
10	058776	4	NT .312-18 HX ZY NL
11	713198	39 cm	SEAL 3/8 X 3/4
12	604324	4	CS .250-20 X .75 HX FLG
13	121069	1	RS HYDRO GUARD
14	121070	1	LS HYDRO GUARD
15	601758	2	CN .375-16 X .20 MAX THK
16	552848	1	SEAT SUPPORT (WITH SEAL)
17	602407	1	HUSTLER ID DECAL
18	552856	1	FOOTREST (WITH DECAL)
19	029629	2	CS .375-16 X .75 HX FLK

NOTES:

SEAL LENGTH	
	13 cm

1. Torque to 23 N•m.

Seat Service Parts

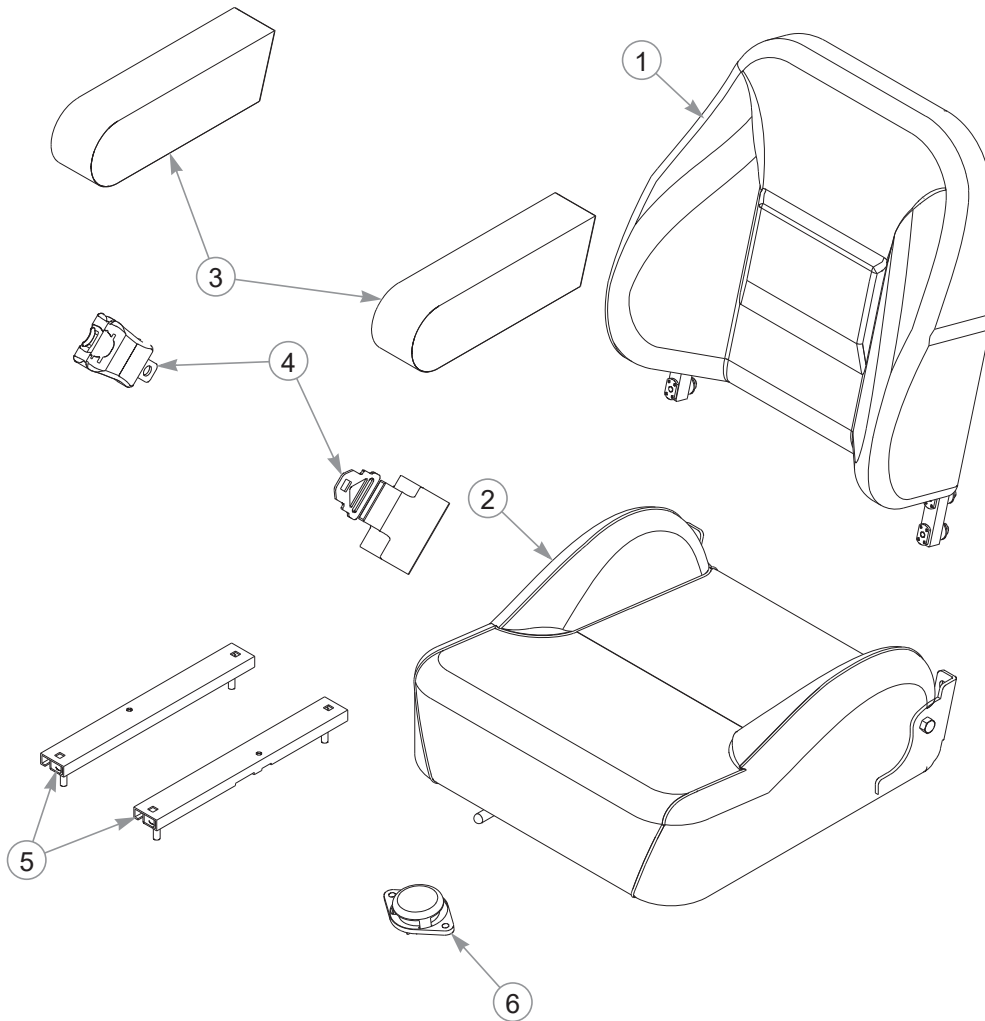

INDEX NO.	PART NO.	QTY.	DESCRIPTION
1	605614	1	SEAT BACK
2	605613	1	SEAT BOTTOM
3	605615	1	ARM REST (PAIR)
4	604945	1	SEAT BELT (SET)
5	604944	1	SEAT SLIDES (PAIR)
6	603148	1	SEAT SWITCH

NOTES:

This page intentionally left blank.

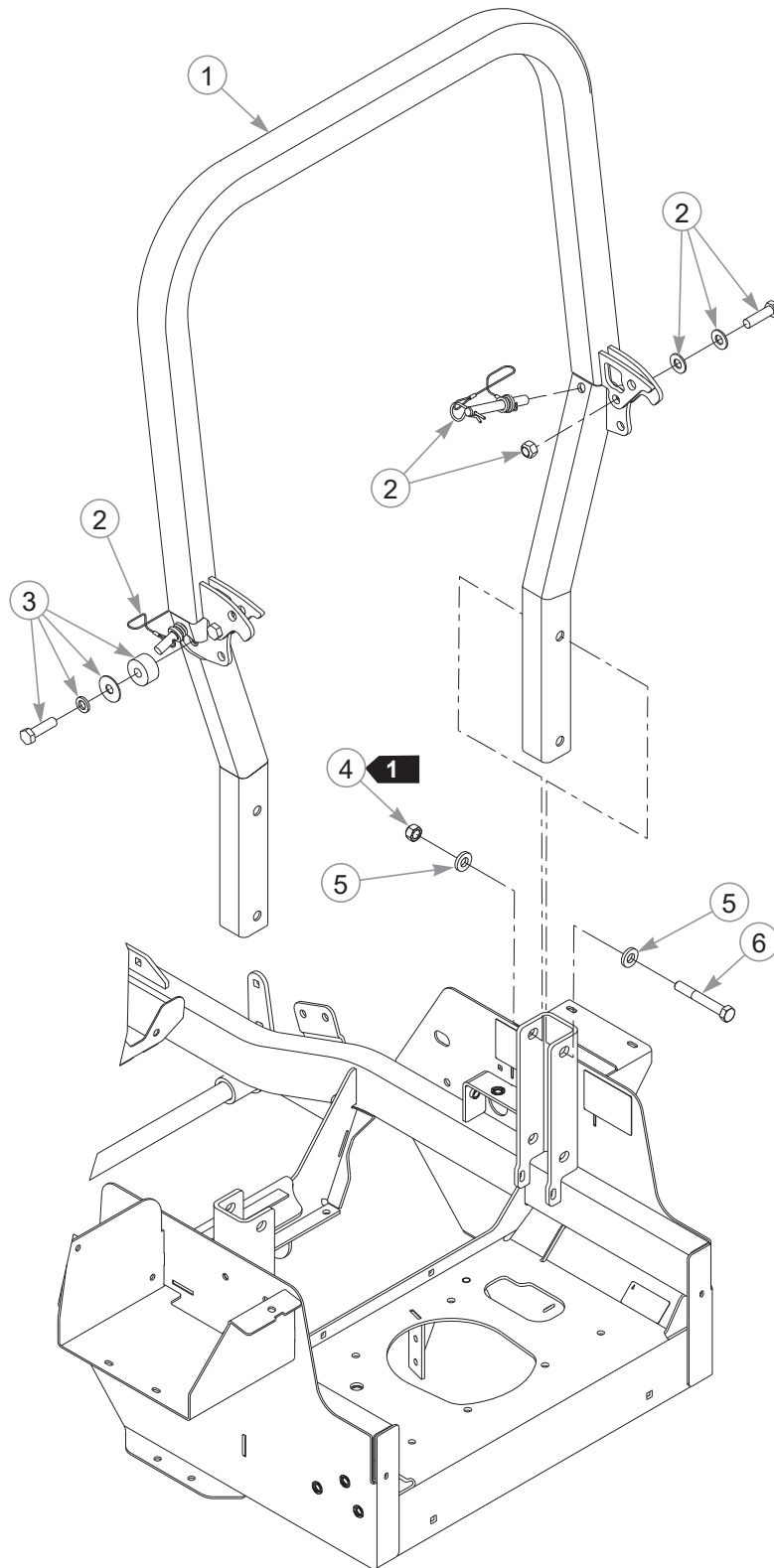

ROPS

INDEX NO.	PART NO.	QTY.	DESCRIPTION
1	605479	1	ROPS KIT
2	605044	1	ROPS HARDWARE KIT
3	605646	2	POLY STOP KIT
4	023317	4	NT .500-13 UNT LK G8
5	767962	8	FW .531 X 1.063 X .175
6	061812	4	CS .500-13 X 3.50 HX G5

NOTES:

1. Torque to 99 N•m.

